



M+S HYDRAULIC

HYDRAULIC MOTORS

MS
MT
MV



DISC VALVE HYDRAULIC MOTORS

CONTENTS

	Page
<input type="checkbox"/> Hydraulic Motors Series MS	4
<input type="checkbox"/> Hydraulic Motors Series MT	25
<input type="checkbox"/> Hydraulic Motors Series MV	39
<input type="checkbox"/> Motor Additional Options	51
<input type="checkbox"/> Motors with Speed Sensor	52
<input type="checkbox"/> Application Calculations	54

DISC VALVE HYDRAULIC MOTORS

GENERAL INFORMATION:

Orbit motors convert hydraulic energy (pressure, oil flow) into mechanical energy (torque, speed). Hydraulic orbit motors operate on the principle of an internal gear (rotor) rotating within a fixed external gear (stator). The internal gear transmits the torque generated by the application of pressure from hydraulic oil fed into motor which is then delivered via the motor's output shaft. Orbit motors have high starting torque and constant output torque at wide speed range. The output shaft runs on tapered roller bearings and can absorb high axial and radial forces.

DISTRIBUTOR VALVE

MS, MT, MV series motors have disk valve: the distributor valve has been separated from output shaft and is driven by short cardan shaft. A balance plate counterbalances the hydraulic forces around the distributor valve. It gives the motors high efficiency- even at high pressures, and good starting characteristics.

GEAR WHEEL SET

There are two forms of gear wheel set: Gerotor set has plain teeth and Roll-gerotor set with teeth fitted with rollers. MS, MT, MV series motors have roll-gerotor set. The rollers reduce local stress and the tangential reaction forces on the rotor reducing friction to a minimum. This gives long operating life and better efficiency even at continuous high pressures.

FEATURES:

Standard Motor

The standard motor mounting flange is located as close to the output shaft as possible. This type of mounting supports the motor close to the shaft load. This mounting flange is also compatible with many standard gear boxes.

Wheel Motor

The wheel motor mounting flange is located near the center of the motor which permits part or all of the motor to be located inside the wheel or roller hub. In traction drive applications, loads can be positioned over the motor bearings for best bearing life. This wheel motor mounting flange provides design flexibility in many applications.

Short Motor

This motor is assembled without the output shaft, bearings and bearing housing and has the same drive components as the standard motors. The short motor is especially suited for applications such as gear boxes, winch, reel and roll drives. Short motor applications must be designed with a bearing supported internal spline to mate with the short motor drive. Product designs using these hydraulic motors provide considerable cost savings.

Low Leakage

LL Series hydraulic motors are designed to operate at the whole standard range of working conditions (pressure drop and frequency of rotation), but with considerable decreased volumetric losses in the drain ports. This motors are suitable for hydraulic systems with series-connected motors with demands for low leakage.

Low Speed Valve

LSV feature optimizes the motor for low-speed performance. Motors with this valving provide very low speed while maintaining high torque. They are designed to run continuously at low speed (up to 200 RPM) at normal pressure drop and reduced flow. Optimal run is guaranteed at frequency of rotation from 20 to 50 RPM. Motors with this valving have an increased starting pressure and are not recommended for using at pressure drop less than 40 bar.

High Pressure Shaft Seal

The high pressure shaft seals allow the motors to withstand high case pressures at high speeds without external drain line.

Motors with Speed Sensor

Motors are available with integrated inductive speed sensor. The output signal is a standardized voltage signal that can be used to control the speed of a motor. The torque and the radial load of the motor are not affected by the installation of speed sensor.

HYDRAULIC MOTORS MS



APPLICATION

- » Conveyors
- » Metal working machines
- » Agricultural machines
- » Road building machines
- » Mining machinery
- » Food industries
- » Special vehicles etc.

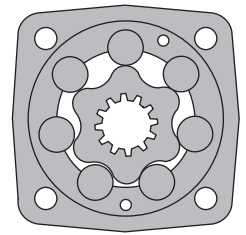
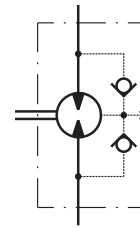

CONTENTS

Specification data	5÷6
Function diagrams	7÷12
Dimensions and mounting	13÷16
Tacho connection	16
Permissible Shaft Seal pressure.....	16
Shaft extensions	17
Motor with Drum brake- MSB	18
Permissible shaft loads	19
Function diagram for MSB	19
Dimensions and mounting- MSS, V, U	20÷23
Internal Spline data	23
Order code	24

OPTIONS

- » Model - Disc valve, roll-gerotor
- » Flange and wheel mount
- » Short motor
- » Motor with Drum Brake
- » Tacho connection
- » Speed sensing
- » Side and rear ports
- » Shafts - straight, splined and tapered
- » SAE, Metric and BSPP ports
- » Other special features

GENERAL

Max. Displacement, cm ³ /rev [in ³ /rev]	564,9 [34.47]
Max. Speed, RPM	1000
Max. Torque, daNm [lb-in]	cont.: 85 [7520] int.: 99 [8760]
Max. Output, kW [HP]	23 [30.8]
Max. Pressure Drop, bar [PSI]	cont.: 210 [3050] int.: 275 [3990]
Max. Oil Flow, lpm [GPM]	90 [24]
Min. Speed, RPM	5
Permissible Shaft Loads, daN [lbs]	P _a =500 [1125]
Pressure fluid	Mineral based- HLP(DIN 51524) or HM(ISO 6743/4)
Temperature range, °C [°F]	-40÷140 [-40÷284]
Optimal Viscosity range, mm ² /s [SUS]	20÷75 [98÷347]
Filtration	ISO code 20/16 (Min. recommended fluid filtration of 25 microns)

Oil flow in drain line

Pressure drop bar [PSI]	Viscosity mm ² /s [SUS]	Oil flow in drain line lpm [GPM]
140 [2030]	20 [98]	1,5 [.396]
	35 [164]	1 [.264]
210 [3045]	20 [98]	3 [.793]
	35 [164]	2 [.528]

Pressure Losses

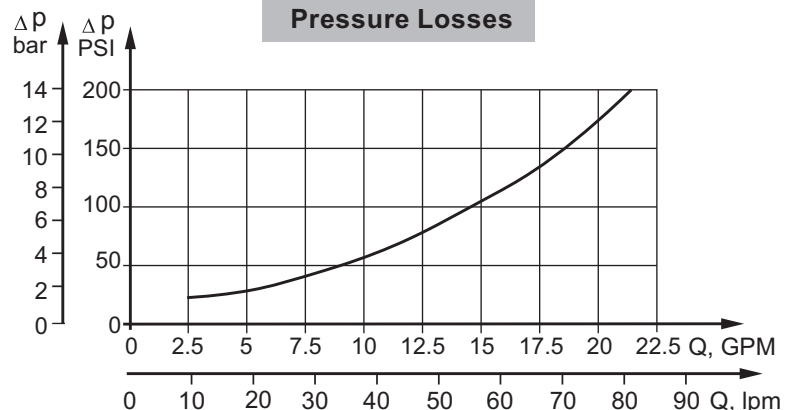

SPECIFICATION DATA

Type	MS 80	MS 100	MS 125	MS 160	MS 200	
Displacement, cm³/rev [in³/rev]	80,5 [4.91]	100 [6.1]	125,7 [7.67]	159,7 [9.74]	200 [12.2]	
Max. Speed, [RPM]	cont.	810	750	600	470	375
	Int.*	1000	900	720	560	450
Max. Torque daNm [lb-in]	cont.	24 [2120]	30,5 [2700]	37,5 [3320]	49 [4340]	61 [5400]
	Int.*	31 [2740]	39 [3450]	49 [4340]	60 [5310]	72 [6370]
Max. Output kW [HP]	cont.	15,5 [20.8]	18 [24.1]	18 [24.1]	16,5 [22.1]	16,5 [22.1]
	int.*	19,5 [26.2]	22,8 [30.2]	22,5 [30.2]	23 [30.8]	22 [29.52]
Max. Pressure Drop bar [PSI]	cont.	210 [3050]	210 [3050]	210 [3050]	210 [3050]	210 [3050]
	Int.*	275 [3990]	275 [3990]	275 [3990]	275 [3990]	275 [3990]
	peak**	295 [4280]	295 [4280]	295 [4280]	295 [4280]	295 [4280]
Max. Oil Flow lpm [GPM]	cont.	65 [17]	75 [20]	75 [20]	75 [20]	75 [20]
	Int.*	80 [21]	90 [24]	90 [24]	90 [24]	90 [24]
Max. Inlet Pressure bar [PSI]	cont.	230 [3340]	230 [3340]	230 [3340]	230 [3340]	230 [3340]
	Int.*	295 [4280]	295 [4280]	295 [4280]	295 [4280]	295 [4280]
	peak**	300 [4350]	300 [4350]	300 [4350]	300 [4350]	300 [4350]
Max. Return Pressure with Drain Line bar [PSI]	cont.	140 [2030]	140 [2030]	140 [2030]	140 [2030]	140 [2030]
	Int.*	175 [2540]	175 [2540]	175 [2540]	175 [2540]	175 [2540]
	peak**	210 [3050]	210 [3050]	210 [3050]	210 [3050]	210 [3050]
Max. Starting Pressure with Unloaded Shaft, bar [PSI]		12 [175]	10 [145]	10 [145]	8 [115]	8 [115]
Min. Starting Torque daNm [lb-in]	at max. press. drop cont.	18 [1590]	23 [2040]	29 [2570]	37 [3270]	47 [4160]
	at max. press. drop Int.*	23,5 [2080]	30 [2660]	38 [3360]	46 [4070]	56 [4960]
Min. Speed***, [RPM]		10	10	8	8	6
Weight, kg [lb] For Rear Ports + 0,40 [.88]	MS(F)	9,9 [21.8]	10,1 [22.2]	10,4 [22.9]	10,8 [23.8]	11,2 [24.7]
	MSW	10,4 [22.9]	10,6 [23.3]	10,9 [24]	11,3 [24.6]	11,7 [25.8]
	MSS	7,9 [17.4]	8,1 [17.8]	8,4 [18.5]	8,8 [19.4]	9,2 [20.2]
	MSV	5,8 [12.8]	6 [13.2]	6,3 [13.9]	6,7 [14.8]	7,1 [15.6]
	MSQ	10,3 [22.7]	10,5 [23.2]	10,8 [23.8]	11,2 [24.7]	11,6 [25.6]
	MSB	16,9 [37.3]	17,1 [37.7]	17,4 [38.3]	17,8 [39.2]	18,2 [41.1]

* Intermittent operation: the permissible values may occur for max. 10% of every minute.

** Peak load: the permissible values may occur for max. 1% of every minute.

*** For speeds lower than given, consult factory or your regional manager.

1. Intermittent speed and intermittent pressure must not occur simultaneously.
2. Recommended filtration is per ISO cleanliness code 20/16. A nominal filtration of 25 micron or better.
3. Recommend using a premium quality, anti-wear type mineral based hydraulic oil HLP(DIN51524) or HM (ISO 6743/4).
If using synthetic fluids consult the factory for alternative seal materials.
4. Recommended minimum oil viscosity 13 mm²/s [70 SUS] at 50°C [122°F].
5. Recommended maximum system operating temperature is 82°C [180°F].
6. To assure optimum motor life fill with fluid prior to loading and run at moderate load and speed for 10-15 minutes.

SPECIFICATION DATA (continued)

Type		MS 250	MS 315	MS 400	MS 475	MS 525	MS 565
Displacement, cm³/rev [in³/rev]		250 [15.3]	314,9 [19.2]	397 [24.2]	474,6[28.96]	522,7 [31.88]	564,9[34.47]
Max. Speed, [RPM]	cont.	300	240	190	160	145	130
	Int.*	360	290	230	190	175	160
Max. Torque daNm [lb-in]	cont.	72 [6370]	82,5 [7300]	86,5 [7660]	85 [7520]	85 [7520]	85 [7520]
	Int.*	87 [7700]	100 [8850]	99 [8760]	99 [8760]	99 [8760]	99 [8760]
Max. Output kW [HP]	cont.	14,5 [19.4]	15 [20.1]	11 [14.8]	8,4 [11]	7,6 [10.2]	6,9 [9]
	int.*	18 [24.1]	17 [22.8]	12,5 [16.8]	11,3 [15]	10,4 [13.9]	9,6 [13]
Max. Pressure Drop bar [PSI]	cont.	200 [2900]	200 [2900]	160 [2320]	130 [1880]	115 [1670]	105 [1520]
	Int.*	250 [3630]	240 [3480]	190 [2760]	150 [2180]	135 [1960]	125 [1810]
	peak**	270 [3920]	260 [3770]	210 [3050]	170 [2470]	155 [2250]	145 [2100]
Max. Oil Flow lpm [GPM]	cont.	75 [20]	75 [20]	75 [20]	75 [20]	75 [20]	75 [20]
	Int.*	90 [24]	90 [24]	90 [24]	90 [24]	90 [24]	90 [24]
Max. Inlet Pressure bar [PSI]	cont.	230 [3340]	230 [3340]	230 [3340]	230 [3340]	230 [3340]	230 [3340]
	Int.*	295 [4280]	295 [4280]	295 [4280]	295 [4280]	295 [4280]	295 [4280]
	peak**	300 [4350]	300 [4350]	300 [4350]	300 [4350]	300 [4350]	300 [4350]
Max. Return Pressure with Drain Line bar [PSI]	cont.	140 [2030]	140 [2030]	140 [2030]	140 [2030]	140 [2030]	140 [2030]
	Int.*	175 [2540]	175 [2540]	175 [2540]	175 [2540]	175 [2540]	175 [2540]
	peak**	210 [3050]	210 [3050]	210 [3050]	210 [3050]	210 [3050]	210 [3050]
Max. Starting Pressure with Unloaded Shaft, bar [PSI]		8 [115]	8 [115]	8 [115]	8 [115]	8 [115]	8 [115]
Min. Starting Torque daNm [lb-in]	at max. press. drop cont.	56 [4960]	71 [6280]	71 [6280]	71 [6280]	71 [6280]	71 [6280]
	at max. press. drop Int.*	70 [6200]	85 [7520]	84 [7430]	84 [7430]	84 [7430]	84 [7430]
Min. Speed***, [RPM]		6	5	5	5	5	5
Weight, kg [lb] For Rear Ports + 0,40 [.88]	MS(F)	11,7 [25.8]	12,4 [27.3]	13,1 [29.3]	14,1 [31]	14,6 [32.2]	15 [33.1]
	MSW	12,2 [26.9]	12,9 [28.4]	13,8 [30.4]	14,6 [32.2]	15,1 [33.3]	15,5 [34.1]
	MSS	9,7 [21.4]	10,4 [22.9]	11,3 [24.9]	12,1 [26.7]	12,6 [27.8]	13 [28.6]
	MSV	7,6 [16.7]	8,3 [18.3]	9,2 [20.2]	10 [22]	10,5 [23.1]	10,9 [24]
	MSQ	12,1 [26.7]	12,8 [28.2]	13,7 [30.2]	14,5 [32]	15 [33.1]	15,4 [33.9]
	MSB	18,7 [41.2]	19,4 [42.7]	20,3 [44.7]	21,1 [46.5]	21,6 [47.6]	23 [48.5]

* Intermittent operation: the permissible values may occur for max. 10% of every minute.

** Peak load: the permissible values may occur for max. 1% of every minute.

*** For speeds lower than given, consult factory or your regional manager.

1. Intermittent speed and intermittent pressure must not occur simultaneously.
2. Recommended filtration is per ISO cleanliness code 20/16. A nominal filtration of 25 micron or better.
3. Recommend using a premium quality, anti-wear type mineral based hydraulic oil HLP(DIN51524) or HM (ISO 6743/4).
If using synthetic fluids consult the factory for alternative seal materials.
4. Recommended minimum oil viscosity 13 mm²/s [70 SUS] at 50°C [122°F].
5. Recommended maximum system operating temperature is 82°C [180°F].
6. To assure optimum motor life fill with fluid prior to loading and run at moderate load and speed for 10-15 minutes.

FUNCTION DIAGRAMS

MS 80

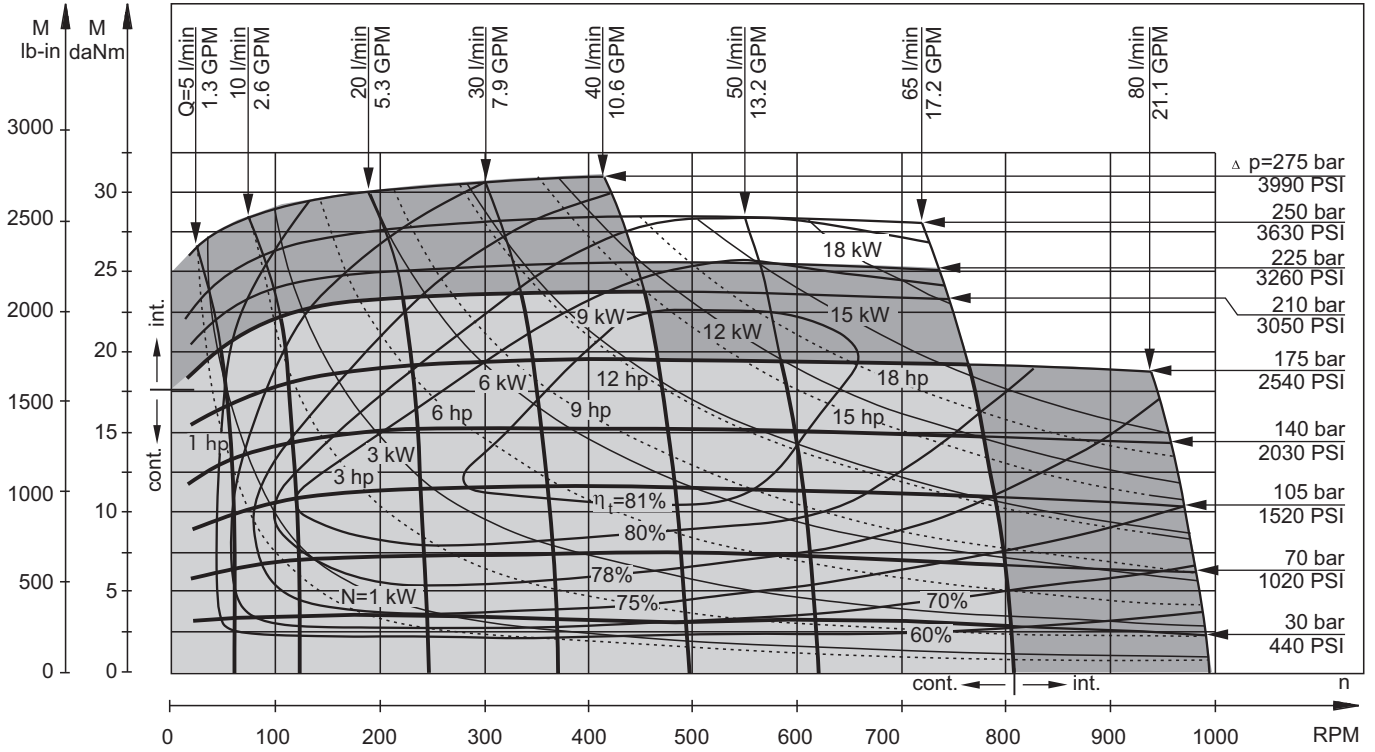

MS 100

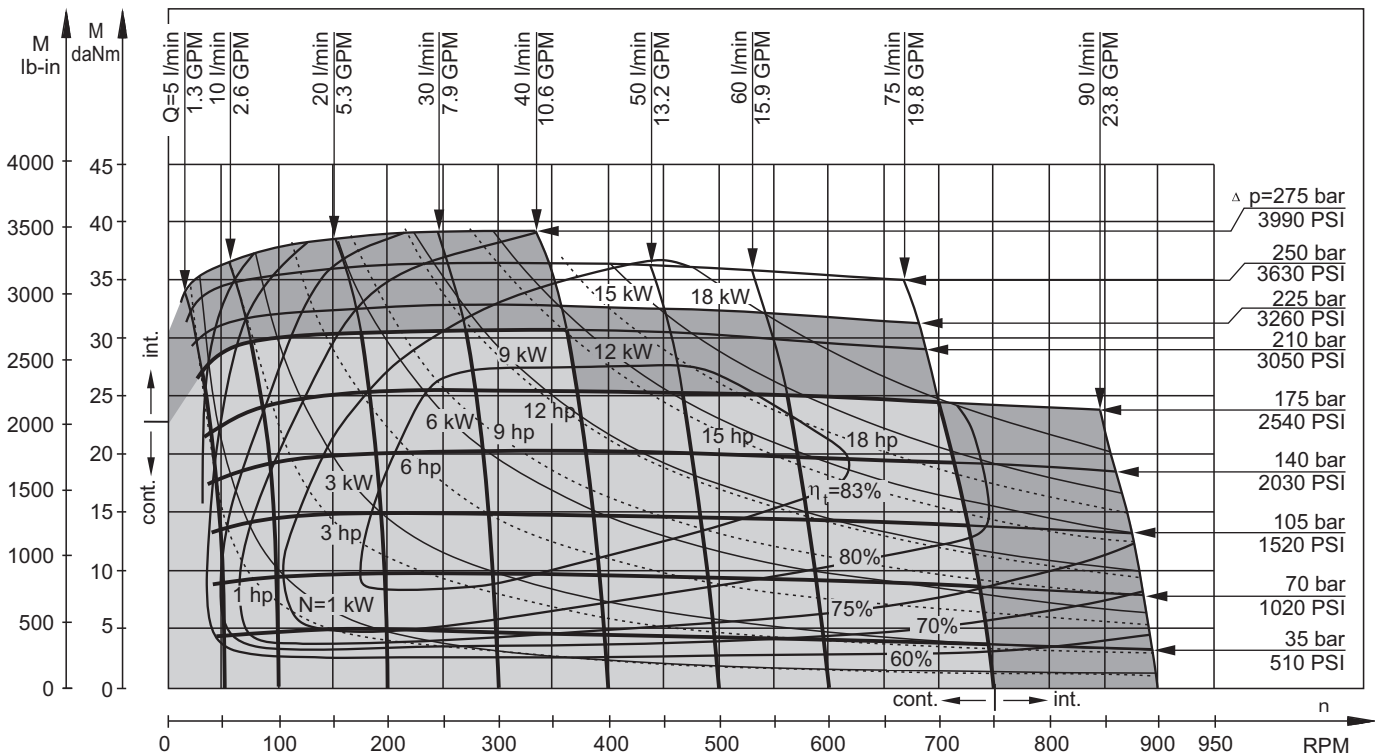

The function diagrams data is for average performance of randomly selected motors at back pressure 5÷10 bar [72.5÷145 PSI] and oil with viscosity of 32 mm²/s [150 SUS] at 50°C [122°F].

FUNCTION DIAGRAMS

MS 125

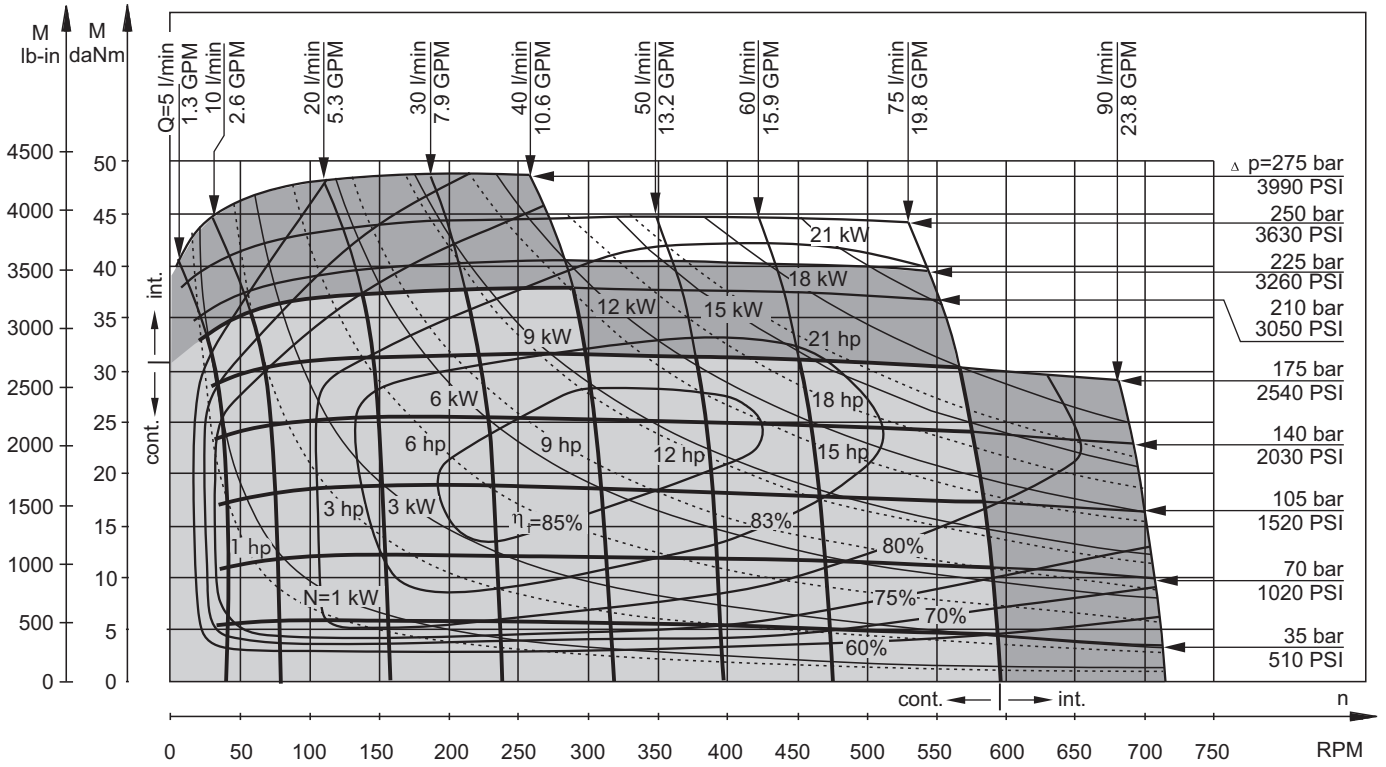

MS 160

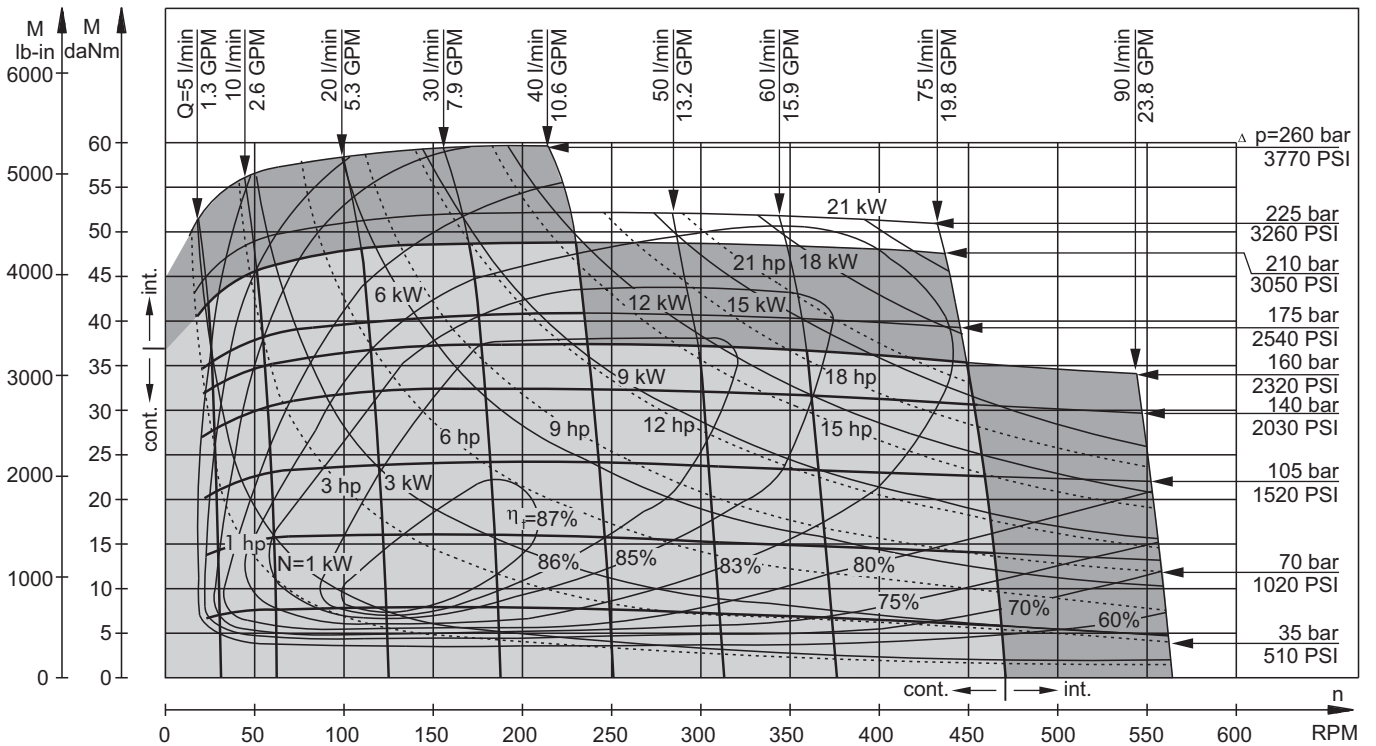

The function diagrams data is for average performance of randomly selected motors at back pressure 5÷10 bar [72.5÷145 PSI] and oil with viscosity of 32 mm²/s [150 SUS] at 50°C [122°F].

FUNCTION DIAGRAMS

MS 200

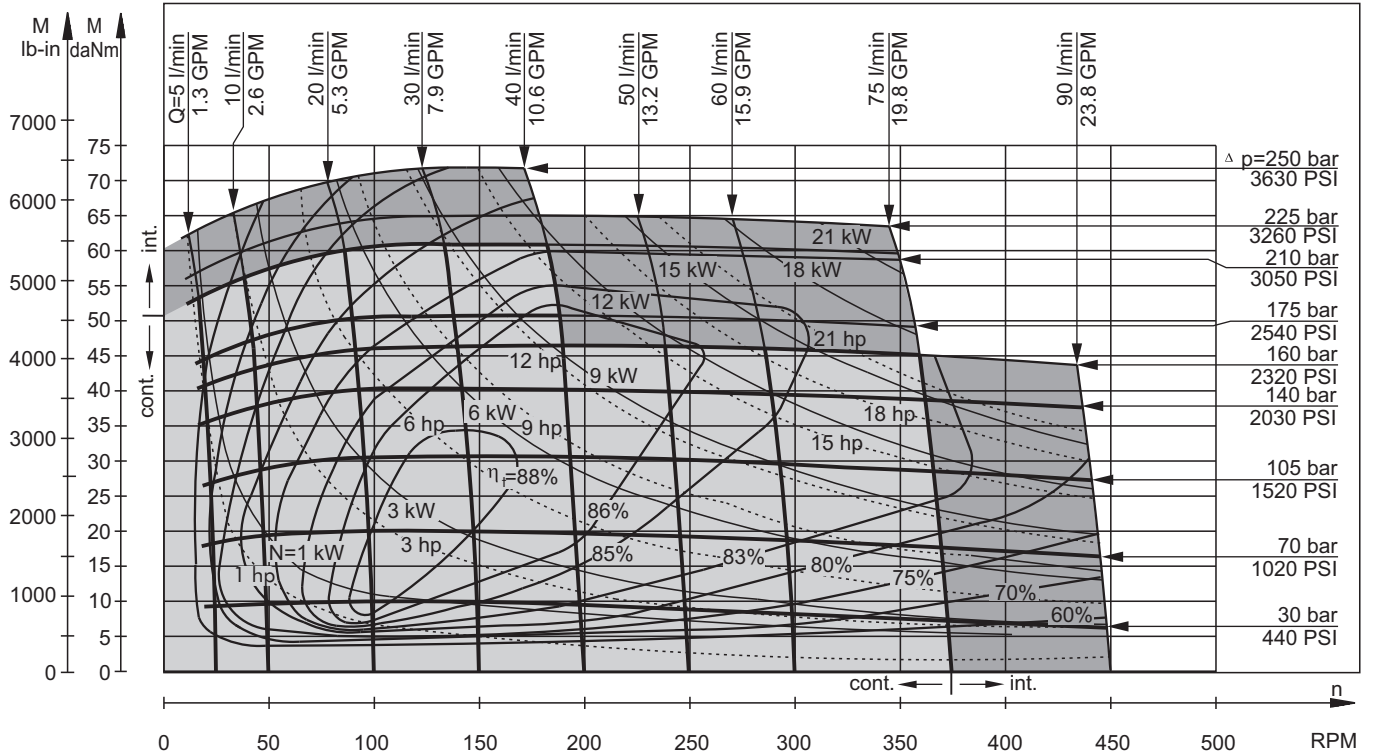

MS 250

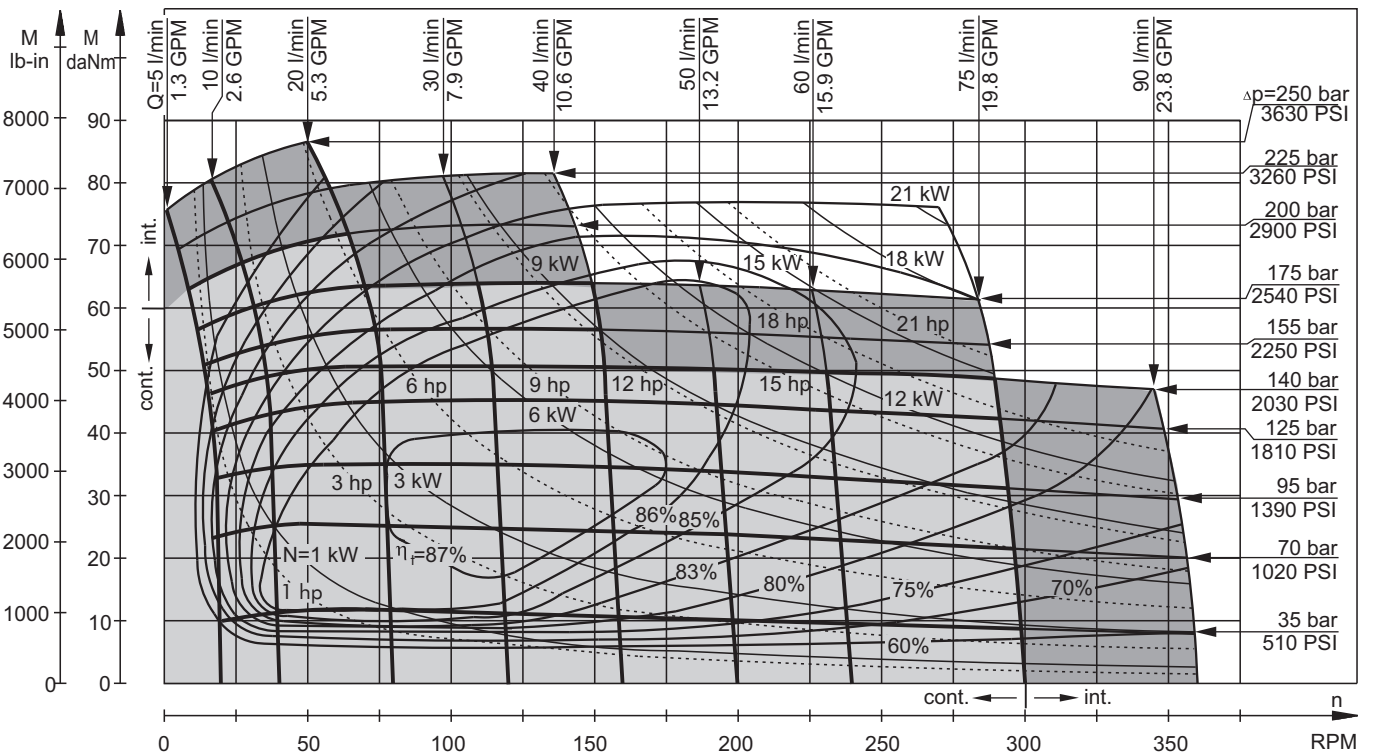

The function diagrams data is for average performance of randomly selected motors at back pressure 5÷10 bar [72.5÷145 PSI] and oil with viscosity of 32 mm²/s [150 SUS] at 50°C [122°F].

FUNCTION DIAGRAMS

MS 315

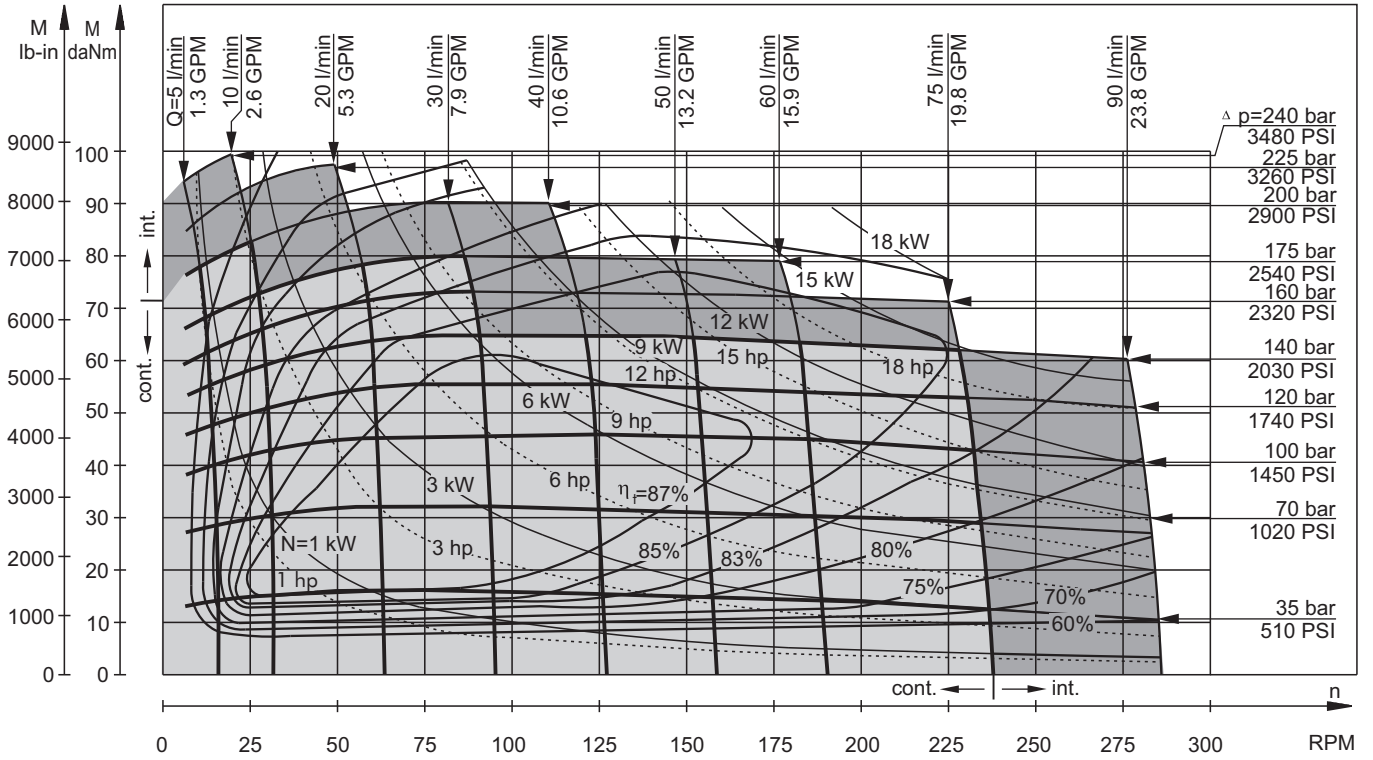

MS 400

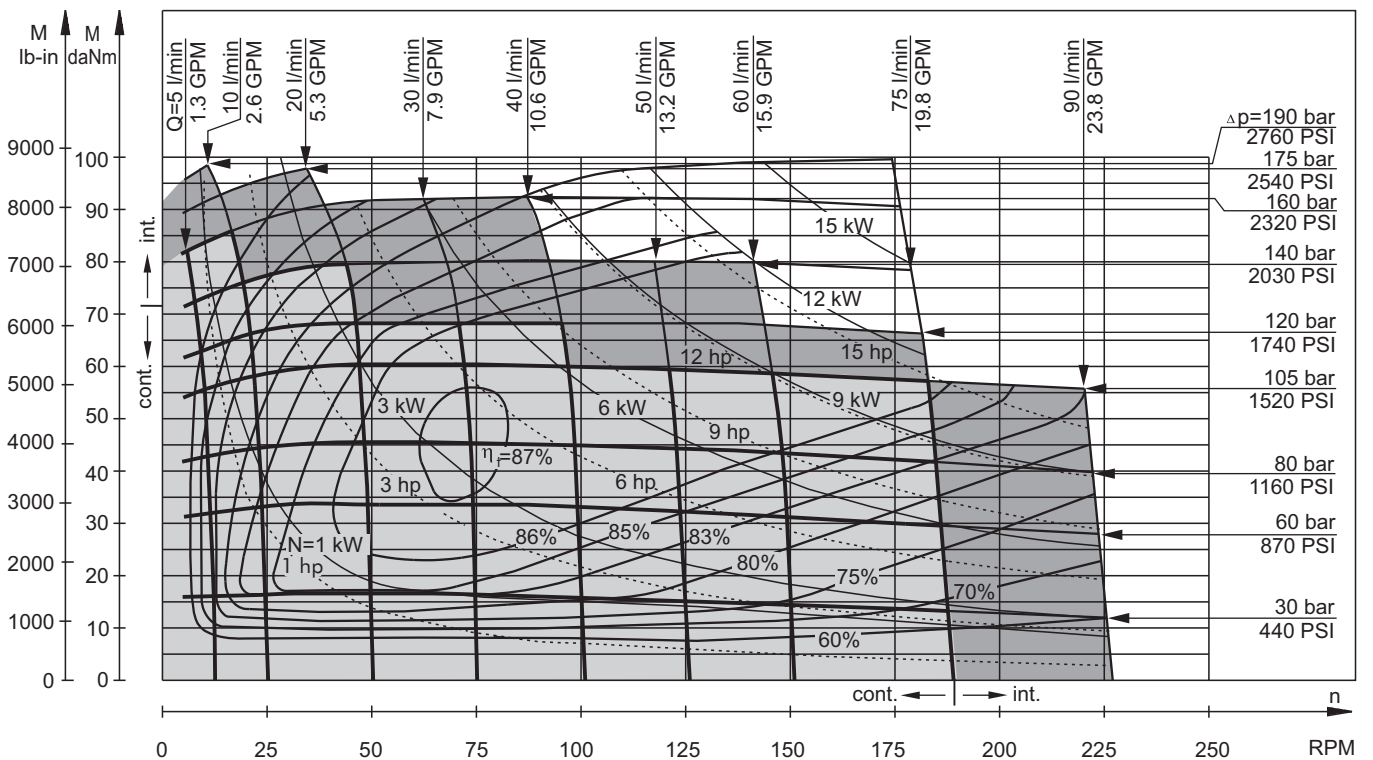

The function diagrams data is for average performance of randomly selected motors at back pressure 5÷10 bar [72.5÷145 PSI] and oil with viscosity of 32 mm²/s [150 SUS] at 50°C [122°F].

FUNCTION DIAGRAMS

MS 475

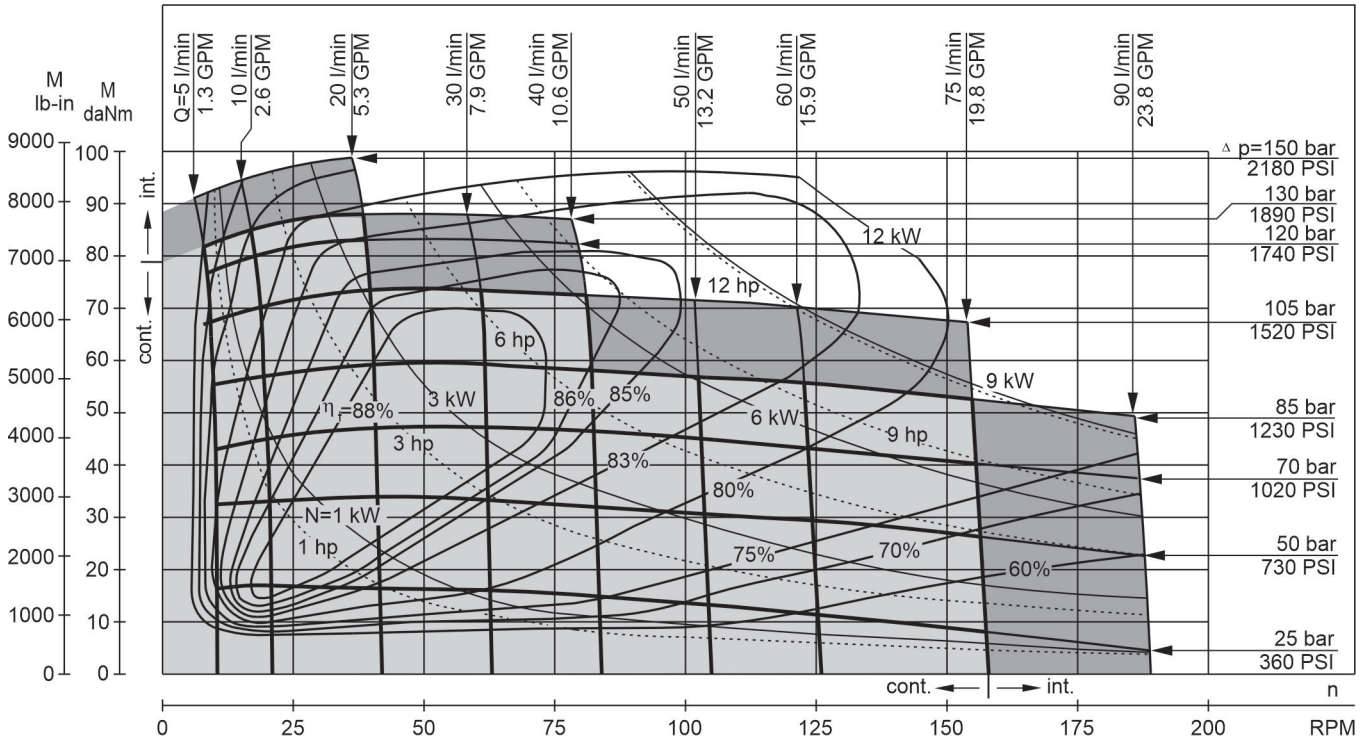

MS 525

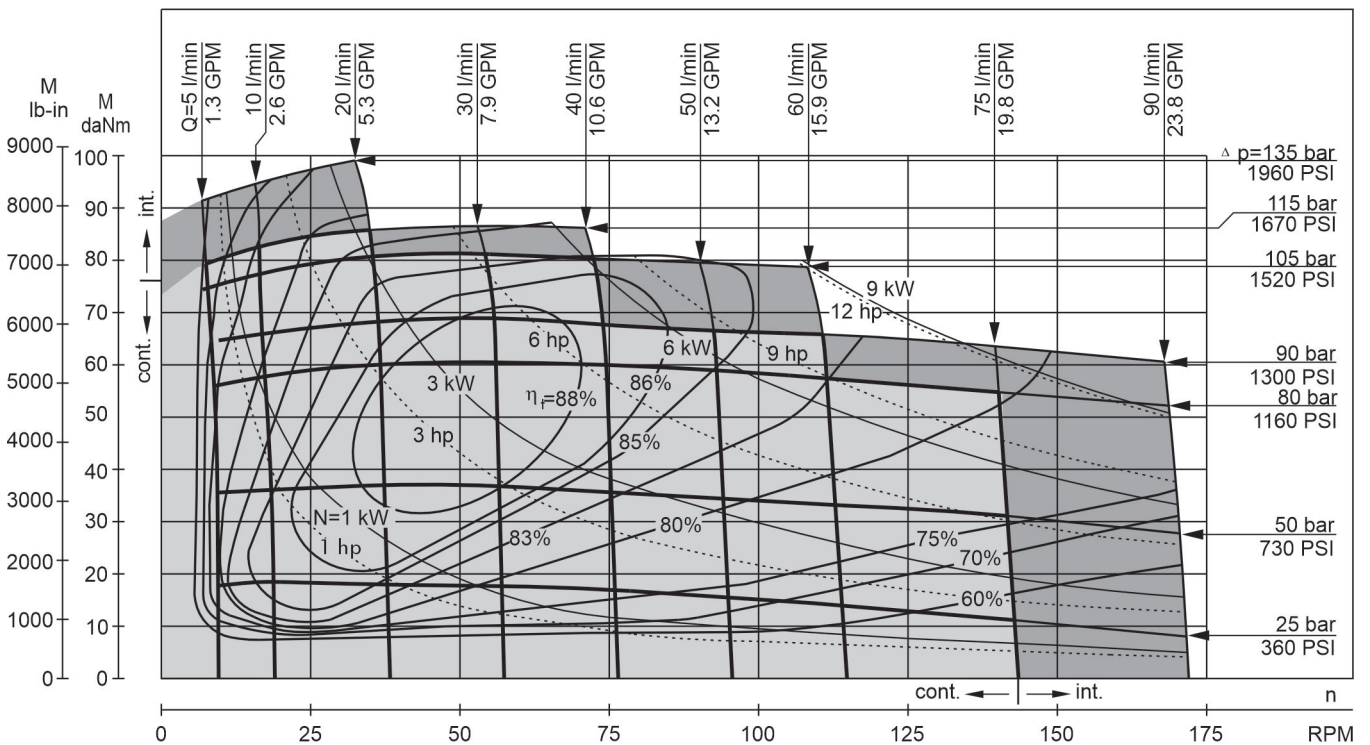

The function diagrams data is for average performance of randomly selected motors at back pressure 5±10 bar [72.5 PSI±145 PSI] and oil with viscosity of 32 mm²/s [150 SUS] at 50°C [122°F].

FUNCTION DIAGRAMS

MS 565

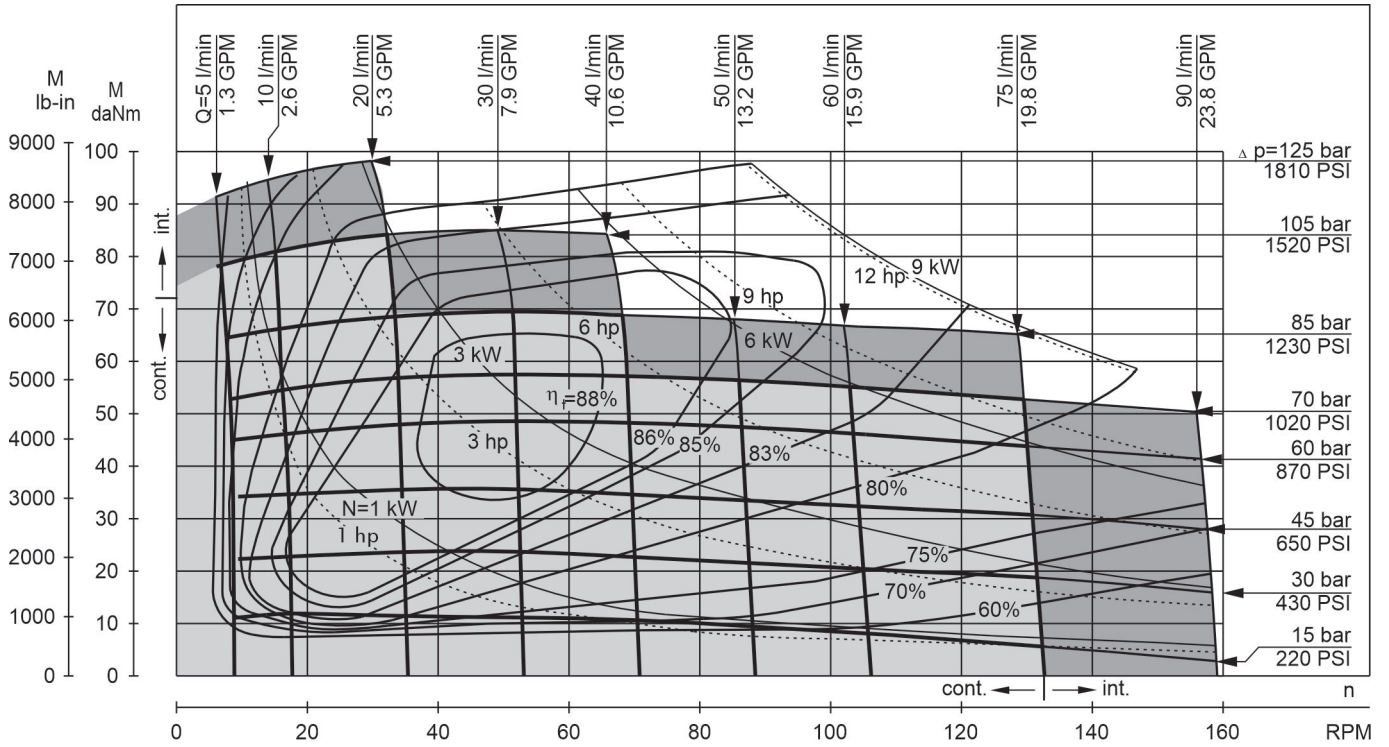

The function diagrams data is for average performance of randomly selected motors at back pressure 5±10 bar [72.5 PSI±145 PSI] and oil with viscosity of 32 mm²/s [150 SUS] at 50°C [122°F].

**DIMENSIONS AND MOUNTING DATA
MS, MSF, MSA, MSW**

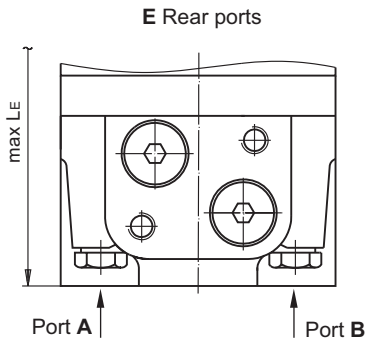
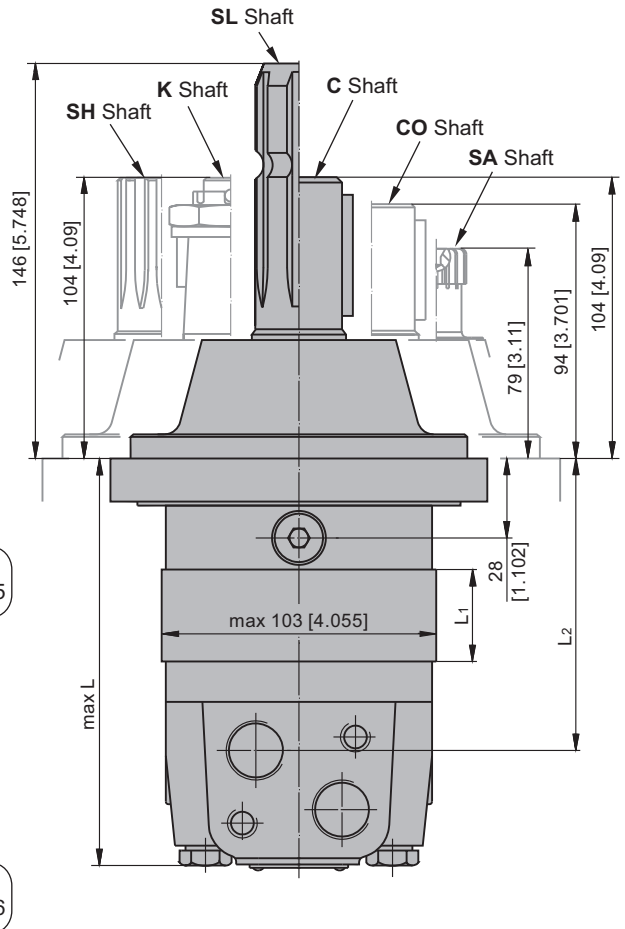
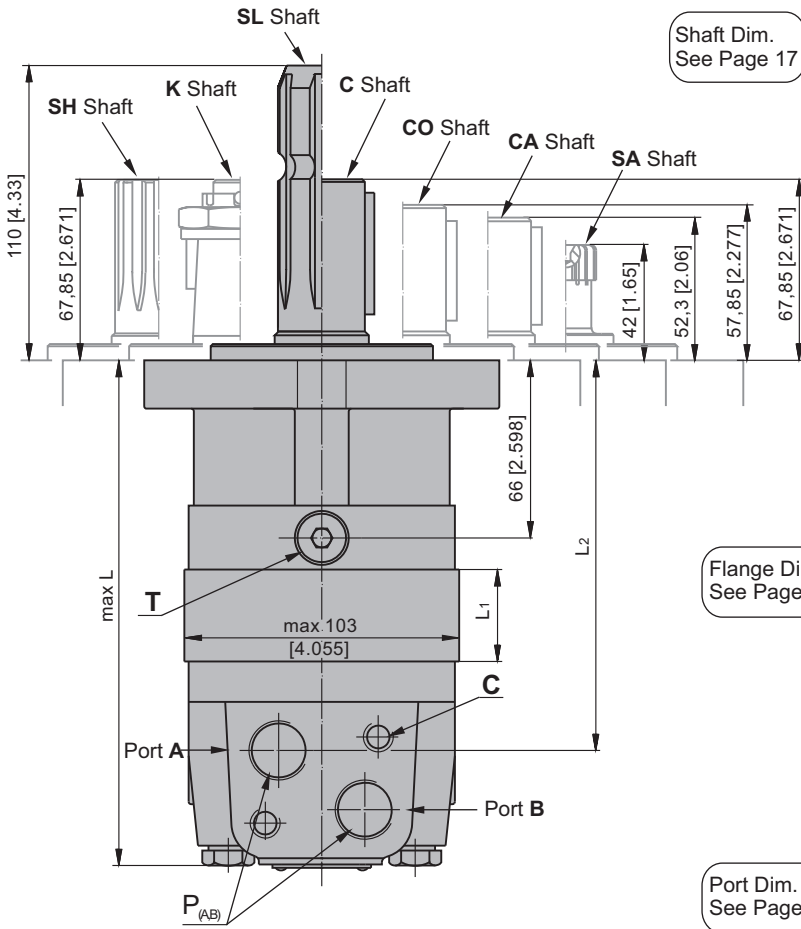

- C** : 2xM10-12 mm [.47 in] depth
- P_(A,B)**: 2xG1/2 or 2xM22x1,5-15 mm [.59 in] depth
- T** : G ¼ or M14x1,5- 12 mm [.47 in] depth (plugged)

Standard Rotation

Viewed from Shaft End
Port **A** Pressurized - **CW**
Port **B** Pressurized - **CCW**

Reverse Rotation

Viewed from Shaft End
Port **A** Pressurized - **CCW**
Port **B** Pressurized - **CW**

Type	L, mm [in]	L ₂ , mm [in]	*L _E , mm [in]	Type	L, mm [in]	L ₂ , mm [in]	*L _E , mm [in]	L ₁ , mm [in]
MS(F, A) 80	168 [6.61]	124 [4.88]	173 [6.81]	MSW 80	129 [5.08]	87 [3.43]	138 [5.43]	14,0 [.55]
MS(F, A) 100	171 [6.73]	128 [5.04]	177 [6.97]	MSW100	133 [5.23]	91 [3.58]	142 [5.59]	17,4 [.69]
MS(F, A) 125	176 [6.93]	132 [5.20]	181 [7.13]	MSW 125	137 [5.39]	95 [3.74]	146 [5.75]	21,8 [.86]
MS(F, A) 160	182 [7.17]	138 [5.43]	187 [7.36]	MSW 160	143 [5.63]	101 [3.98]	152 [5.99]	27,8 [1.09]
MS(F, A) 200	189 [7.44]	145 [5.71]	194 [7.64]	MSW 200	150 [5.91]	108 [4.25]	159 [6.26]	34,8 [1.37]
MS(F, A) 250	197 [7.76]	154 [6.06]	203 [7.99]	MSW 250	159 [6.26]	117 [4.61]	168 [6.62]	43,5 [1.71]
MS(F, A) 315	209 [8.23]	165 [6.50]	214 [8.43]	MSW 315	170 [6.69]	128 [5.04]	179 [7.05]	54,8 [2.16]
MS(F, A) 400	223 [8.78]	179 [7.05]	228 [8.98]	MSW 400	184 [7.24]	143 [5.63]	194 [7.64]	69,4 [2.73]
MS(F, A) 475	237 [9.33]	193 [7.60]	242 [9.53]	MSW 475	198 [7.79]	156 [6.14]	207 [8.15]	82,6 [3.25]
MS(F, A) 525	229 [9.02]	185 [7.28]	234 [9.21]	MSW 525	190 [7.48]	148 [5.83]	199 [7.84]	74,5 [2.93]
MS(F, A) 565	235 [9.25]	191 [7.52]	240 [9.45]	MSW 565	196 [7.72]	154 [6.06]	205 [8.07]	80,2 [3.16]

* - For Rear Ported Motors.

DIMENSIONS AND MOUNTING DATA - MSQ

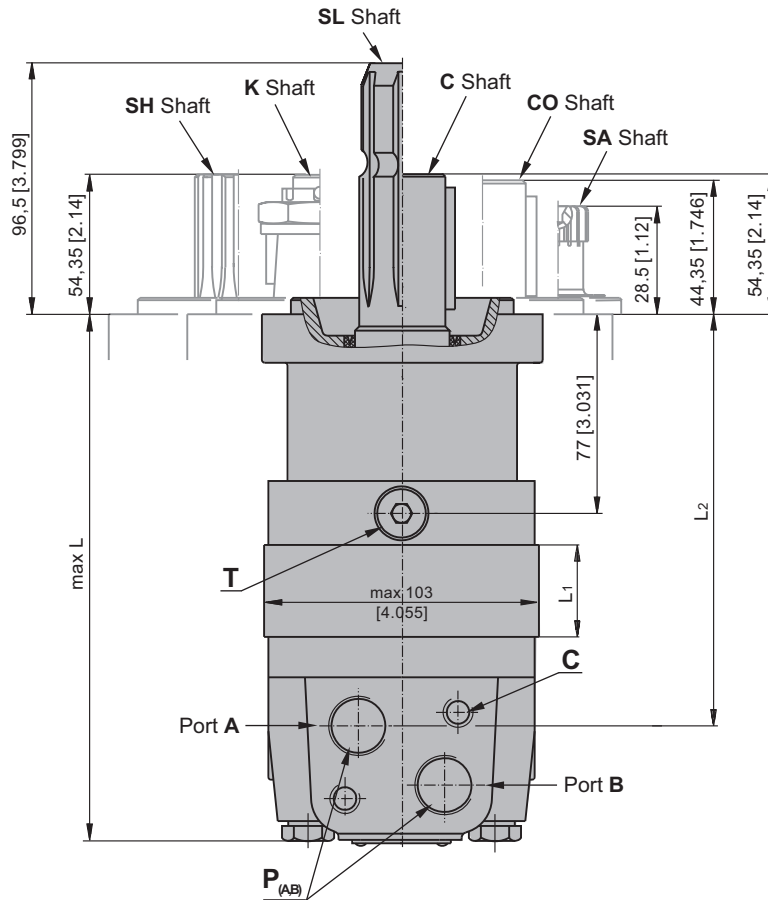

Shaft Dim.
See Page 17

Port Dim.
See Page 16

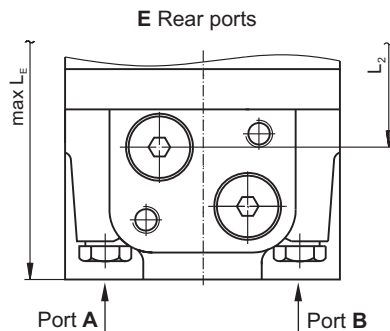

- C** : 2xM10-12 mm [.47 in] depth
- P_(A,B)** : 2xG1/2 or 2xM22x1,5-15 mm [.59 in] depth
- T** : G ¼ or M14x1,5- 12 mm [.47 in] depth (plugged)

Standard Rotation
Viewed from Shaft End
Port A Pressurized - **CW**
Port B Pressurized - **CCW**

Reverse Rotation
Viewed from Shaft End
Port A Pressurized - **CCW**
Port B Pressurized - **CW**

Type	L, mm [in]	L ₂ , mm [in]	*L _E , mm [in]	L ₁ , mm [in]
MSQ 80	179 [7.05]	136 [5.35]	185 [7.28]	14,0 [.55]
MSQ 100	183 [7.21]	140 [5.51]	189 [7.44]	17,4 [.69]
MSQ 125	187 [7.36]	144 [5.67]	193 [7.60]	21,8 [.86]
MSQ 160	193 [7.60]	150 [5.91]	199 [7.83]	27,8 [1.09]
MSQ 200	200 [7.87]	157 [6.18]	206 [8.11]	34,8 [1.37]
MSQ 250	209 [8.23]	166 [6.54]	215 [8.46]	43,5 [1.71]
MSQ 315	220 [8.66]	177 [6.67]	226 [8.90]	54,8 [2.16]
MSQ 400	235 [9.25]	192 [7.56]	241 [9.49]	69,4 [2.73]
MSQ 475	247 [9.72]	205 [8.07]	254 [10.0]	82,6 [3.25]
MSQ 525	240 [9.45]	197 [7.76]	246 [9.69]	74,5 [2.93]
MSQ 565	246 [9.69]	203 [7.99]	252 [9.92]	80,2 [3.16]

* - For Rear Ported Motors.

MOUNTING

SAE A-4 Mount (4 Holes)

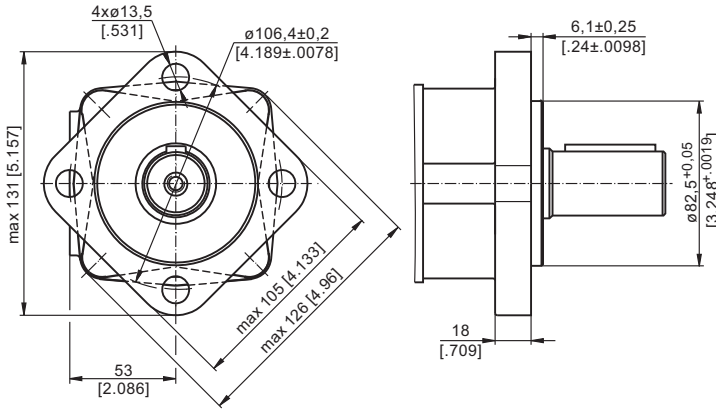

A SAE A-2 Mount (2 Holes)

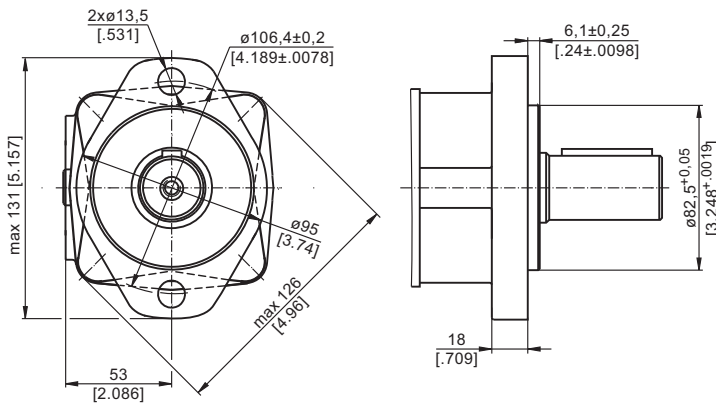

F Magneto Mount (4 Holes)

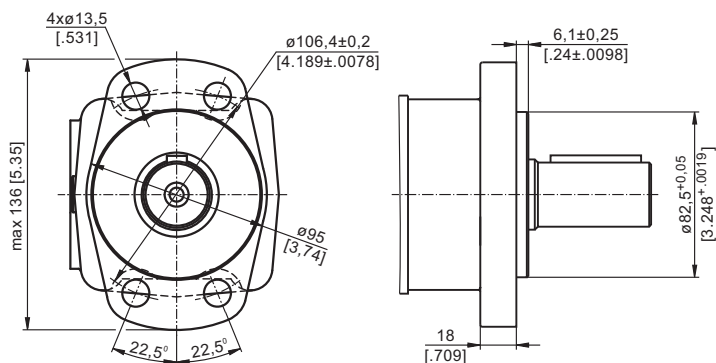

Q Square Mount (4 Holes)

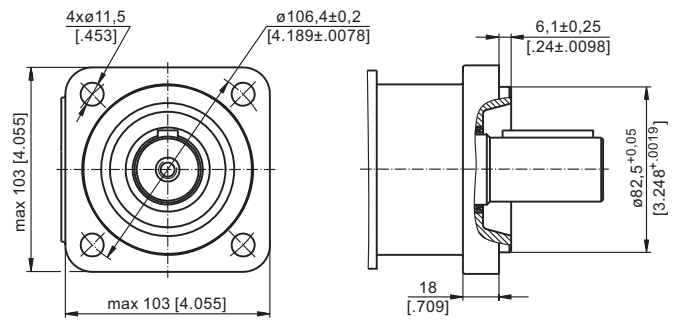

W Wheel Mount

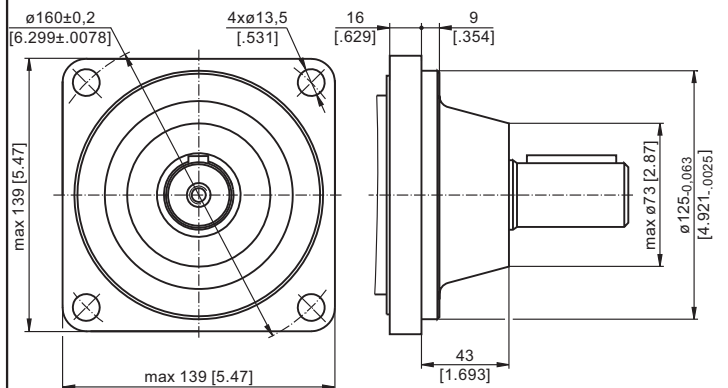

PORTS

Side Ports

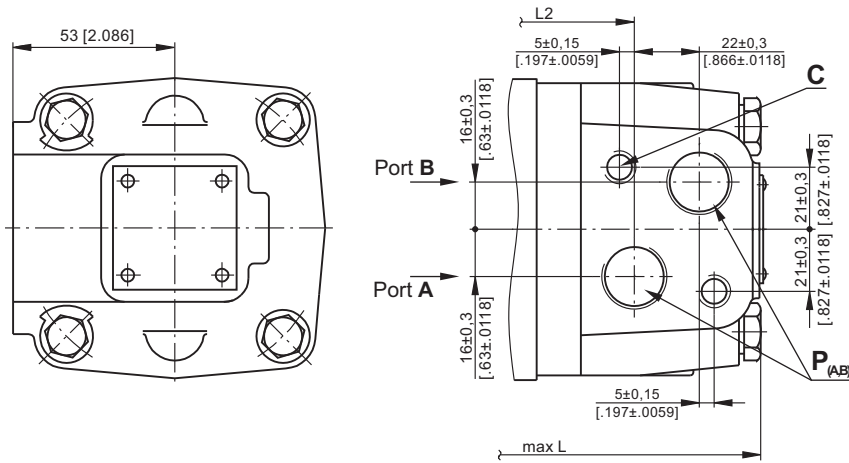

E Rear Ports

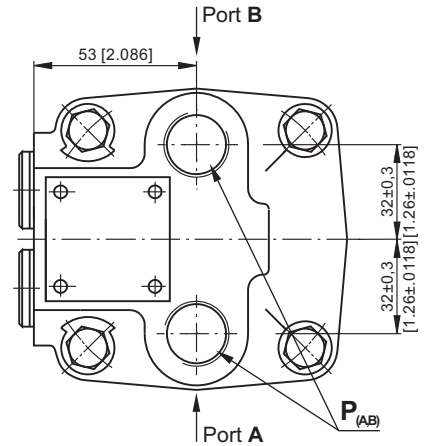

Standard Rotation
Viewed from Shaft End
Port A Pressurized - **CW**
Port B Pressurized - **CCW**

Reverse Rotation
Viewed from Shaft End
Port A Pressurized - **CCW**
Port B Pressurized - **CW**

C : 2xM10-12 mm [.47 in] depth
P_(A,B) : 2xG1/2 or 2xM22x1,5-15 mm [.59 in] depth
T : G ¼ or M14x1,5- 12 mm [.47 in] depth (plugged)

MOTORS WITH TACHO CONNECTION

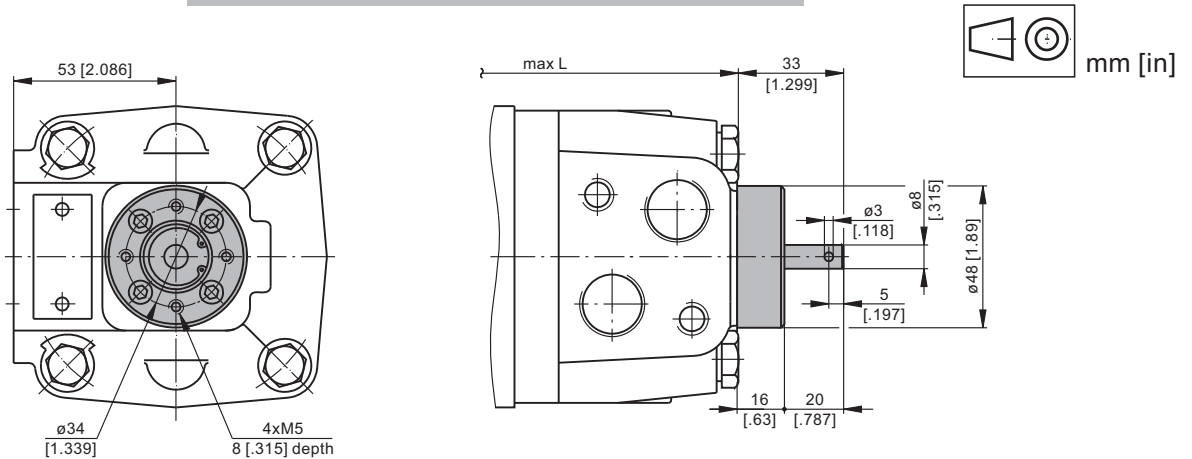

MAX. PERMISSIBLE SHAFT SEAL PRESSURE

Max. return pressure without drain line or
max. pressure in the drain line

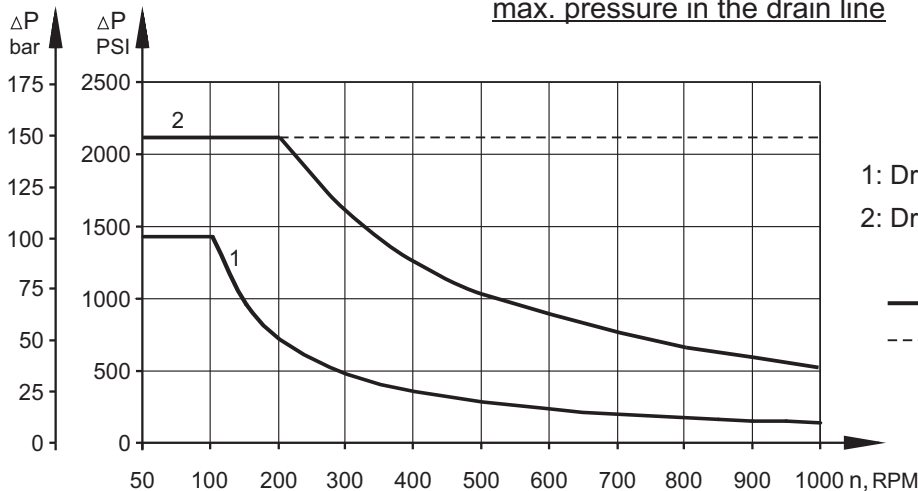

1: Drawing for Standard Shaft Seal
2: Drawing for High Pressure Seal ("U" Seal)
— - continuous operations
- - - - intermittent operations

SHAFT EXTENSIONS

C - $\varnothing 32$ straight, Parallel key A10x8x45 DIN 6885
Max. Torque 77 daNm [6815 lb-in]

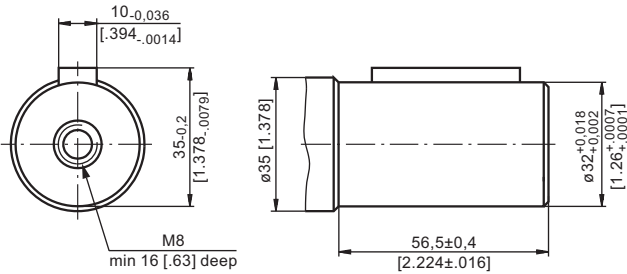

K - tapered 1:10, Parallel key B6x6x20 DIN 6885
Max. Torque 95 daNm [8400 lb-in]

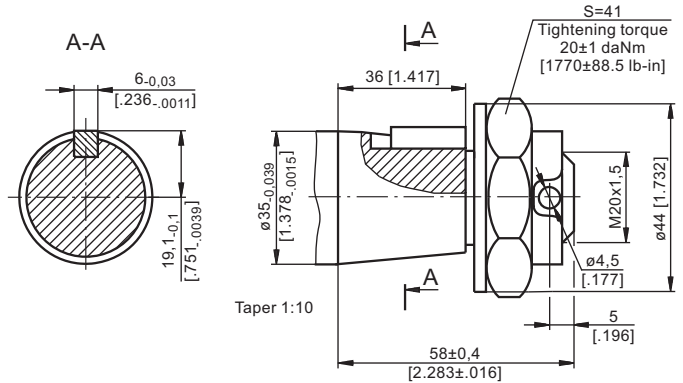

CO - $\varnothing 1\frac{1}{4}$ " straight, Parallel key $\frac{5}{16}$ "x $\frac{5}{16}$ "x $1\frac{1}{4}$ "BS46
Max. Torque 77 daNm [6815 lb-in]

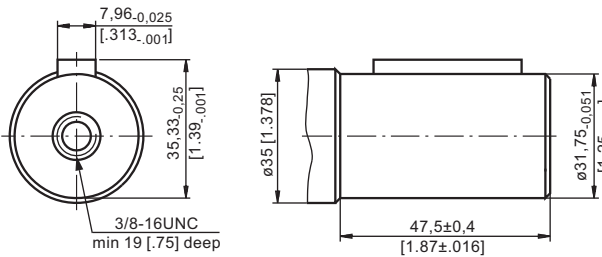

SH - $\varnothing 1\frac{1}{4}$ " splined 14T, DP12/24 ANS B92.1-1970
Max. Torque 95 daNm [8400 lb-in]

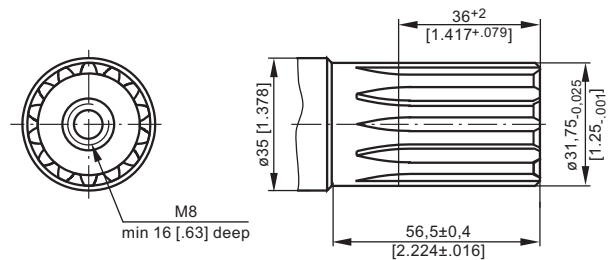

SL - $\varnothing 34,85$ p.t.o. DIN 9611 Form 1
Max. Torque 77 daNm [6815 lb-in]

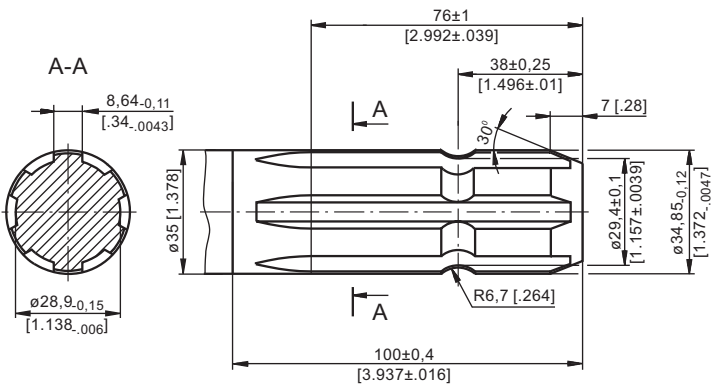

SA - 7/8"-13T splined DP16/32 ANS B92.1-1970
Max. Torque 20 daNm [1770 lb-in]

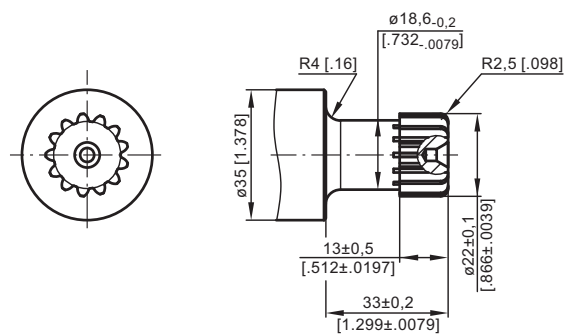

CA - $\varnothing 25$ straight, Parallel key A8x7x32 DIN 6885
Max. Torque 34 daNm [3010 lb-in]

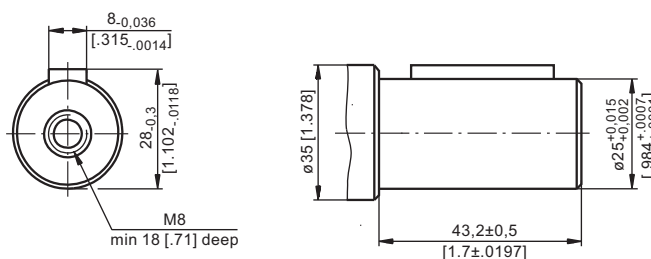

PERMISSIBLE SHAFT LOADS

The output shaft runs in tapered bearings that permit high axial and radial forces. The permissible radial load on the shaft is shown for an axial load of 0 N as function of the distance from the mounting flange to the point of load application. The curves apply to a B10 bearing life of 2000 hours at 100 RPM.

Curve "1" shows max. radial shaft load. Any shaft load exceeding the values shown by the curve will seriously reduce motor life.

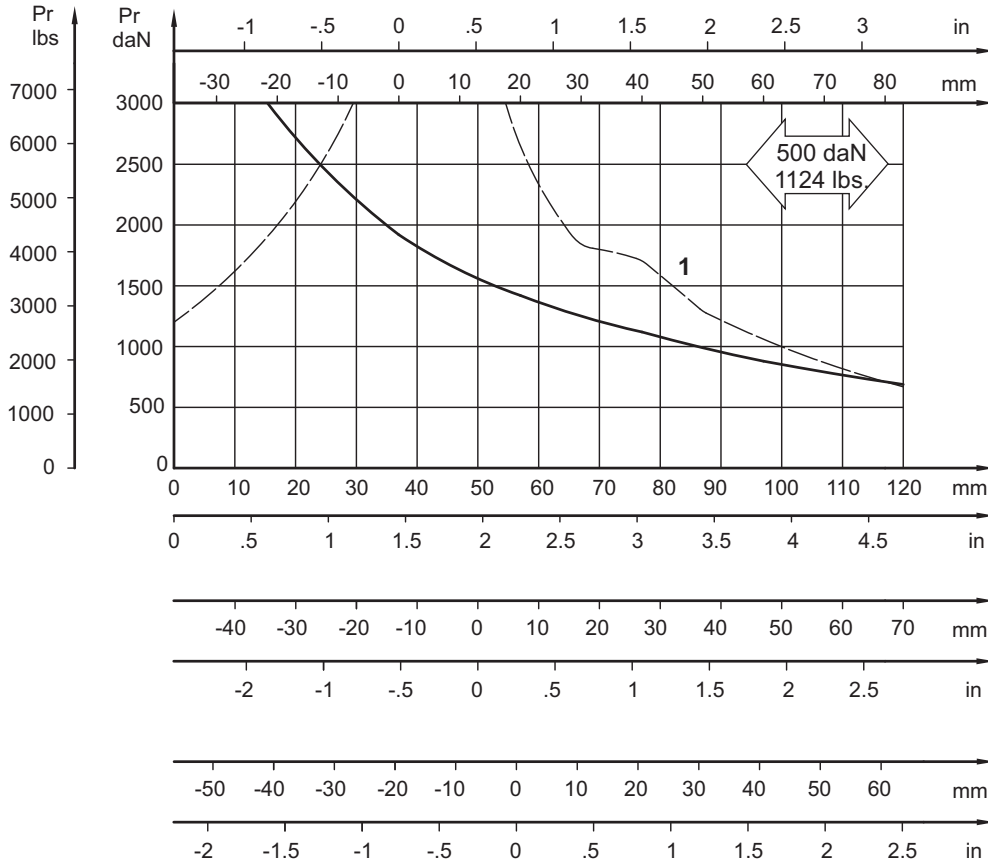

Mounting Flange:

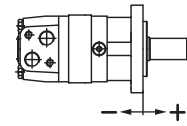

Standard
A-2
Magneto

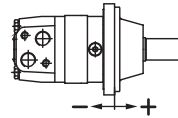

W - Wheel

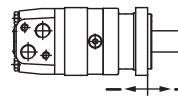

Q - Square

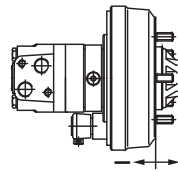

Drum Brake

Shaft: All type shafts except SA

FUNCTION DIAGRAM MSB

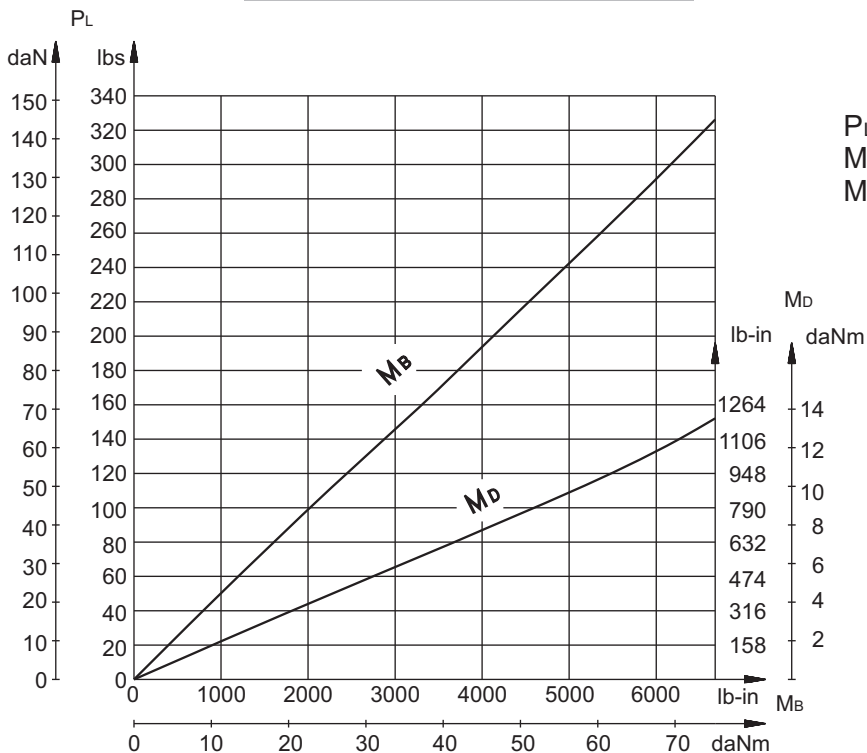

PL - Brake Lever Load
MB - Brake Torque
MD - Brake Lever Torque

DIMENSIONS AND MOUNTING DATA - MSS and MSV

S Short Mount

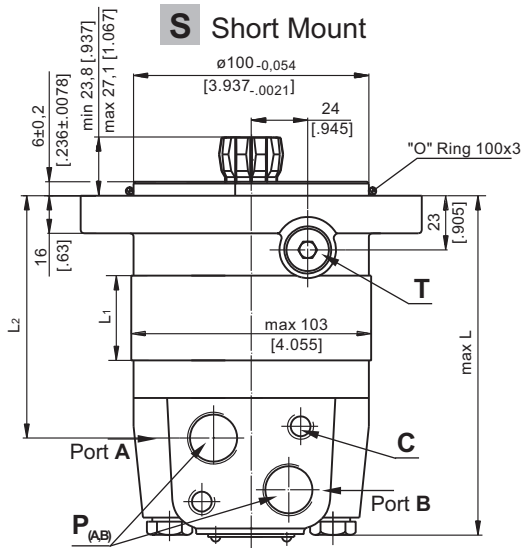

V Very Short Mount

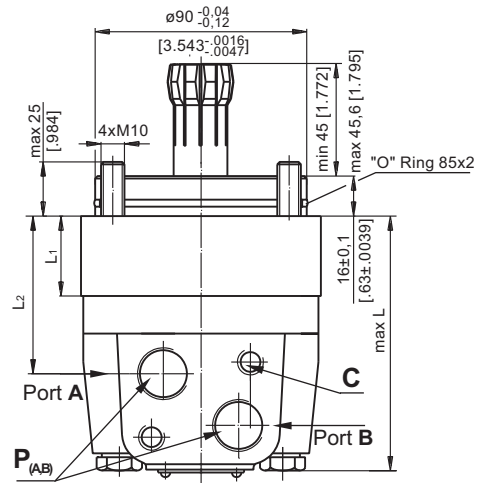

Port Dim.
See Page 16

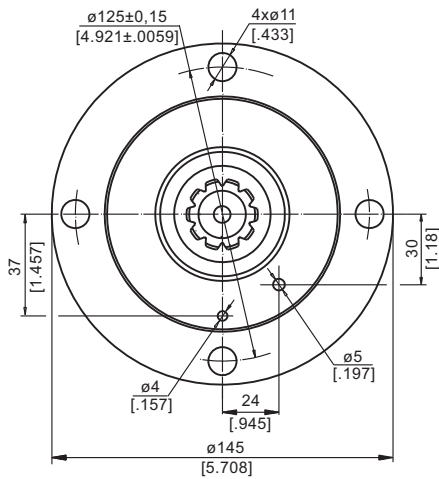

E Rear ports

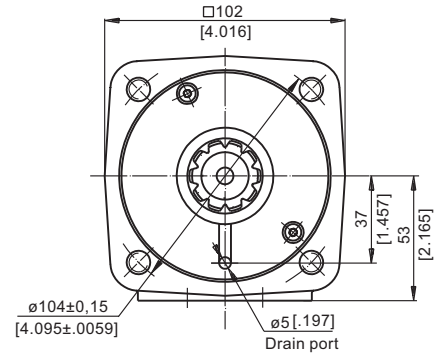
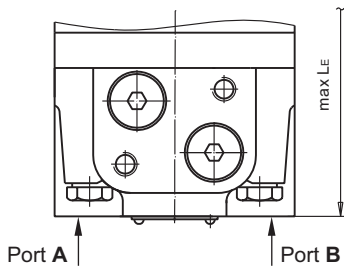

- C** : 2xM10 - 12 mm [.47 in] depth
- P_(A,B)** : 2xG1/2 or 2xM22x1,5 - 15 mm [.59 in] depth
- T** : G 1/4 or M14x1,5 - 12 mm [.47 in] depth (plugged)

Standard Rotation
Viewed from Shaft End
Port A Pressurized - **CW**
Port B Pressurized - **CCW**

Reverse Rotation
Viewed from Shaft End
Port A Pressurized - **CCW**
Port B Pressurized - **CW**

Type	L, mm [in]	L ₂ , mm [in]	*L _E , mm [in]	Type	L, mm [in]	L ₂ , mm [in]	*L _E , mm [in]	L ₁ , mm [in]
MSS 80	125 [4.92]	83 [3.27]	134 [5.28]	MSV 80	91 [3.58]	47 [1.85]	97 [3.82]	14,0 [.55]
MSS 100	129 [5.08]	87 [3.43]	138 [5.43]	MSV 100	94 [3.70]	50,5 [1.99]	100 [3.94]	17,4 [.69]
MSS 125	133 [5.24]	90 [3.54]	141 [5.55]	MSV 125	99 [3.90]	55 [2.17]	105 [4.13]	21,8 [.86]
MSS 160	139 [5.47]	96 [3.78]	147 [5.79]	MSV 160	105 [4.13]	61 [2.40]	111 [4.37]	27,8 [1.09]
MSS 200	146 [5.75]	103 [4.05]	154 [6.06]	MSV 200	112 [4.41]	68 [2.78]	118 [4.64]	34,8 [1.37]
MSS 250	155 [6.10]	112 [4.41]	163 [6.42]	MSV 250	120 [4.72]	76,5 [3.01]	126 [4.96]	43,5 [1.71]
MSS 315	166 [6.54]	123 [4.84]	174 [6.85]	MSV 315	132 [5.20]	88 [3.46]	138 [5.43]	54,8 [2.16]
MSS 400	181 [7.13]	138 [5.43]	189 [7.44]	MSV 400	146 [5.75]	103 [4.05]	153 [6.02]	69,4 [2.73]
MSS 475	194 [7.64]	152 [5.98]	203 [7.99]	MSV 475	160 [6.30]	116 [4.57]	166 [6.54]	82,6 [3.25]
MSS 525	186 [7.32]	144 [5.67]	195 [7.68]	MSV 525	152 [5.98]	108 [4.25]	158 [6.22]	74,5 [2.93]
MSS 565	192 [7.56]	150 [5.91]	201 [7.91]	MSV 565	158 [6.22]	114 [4.49]	164 [6.46]	80,2 [3.16]

* - For Rear Ported Motors.

DIMENSIONS AND MOUNTING DATA - MSU

U Ultra Short Mount

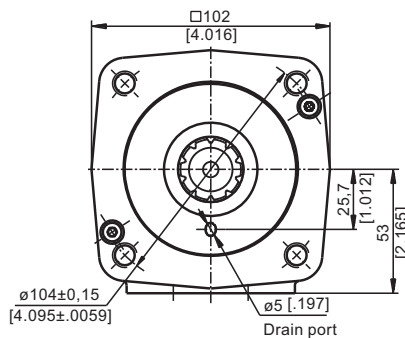
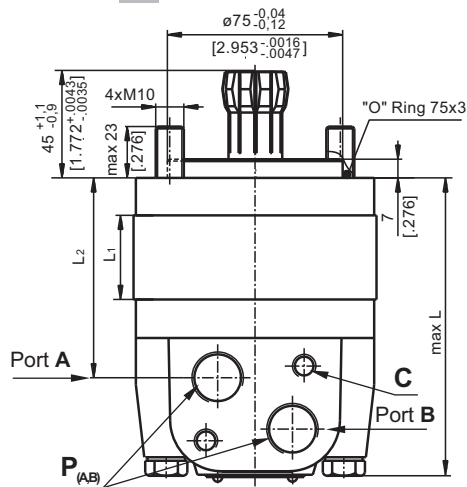

E Rear ports

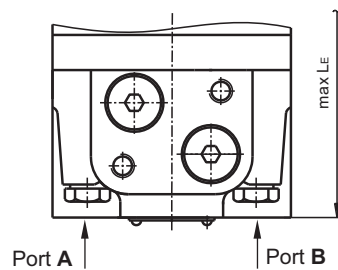

C : 2xM10-12 mm [.47 in] depth
P_(A,B): 2xG1/2 or 2xM22x1,5, 15 mm [.59 in] depth

Standard Rotation
 Viewed from Shaft End
 Port A Pressurized - **CW**
 Port B Pressurized - **CCW**

Reverse Rotation
 Viewed from Shaft End
 Port A Pressurized - **CCW**
 Port B Pressurized - **CW**

Type	L, mm[in]	L ₂ , mm[in]	*L _E , mm[in]	L1, mm[in]
MSU 80	105,5 [4.15]	63 [2.48]	111,5 [4.39]	14,0 [.55]
MSU 100	109 [4.29]	66,5 [2.62]	115 [4.53]	17,4 [.69]
MSU 125	113 [4.45]	71 [2.80]	119 [4.69]	21,8 [.86]
MSU 160	119 [4.69]	77 [3.03]	125 [4.92]	27,8 [1.09]
MSU 200	126 [4.96]	84 [3.31]	132 [5.20]	34,8 [1.37]
MSU 250	135 [5.32]	92,5 [3.64]	141 [5.55]	43,5 [1.71]
MSU 315	146 [5.75]	104 [4.09]	152 [5.98]	54,8 [2.16]
MSU 400	160 [6.30]	119 [4.69]	167 [6.58]	69,4 [2.73]
MSU 475	174 [6.85]	132 [5.20]	180 [7.09]	82,6 [3.25]
MSU 525	166 [6.54]	124 [4.88]	172 [6.77]	74,5 [2.93]
MSU 565	172 [6.77]	130 [5.12]	178 [7.01]	80,2 [3.16]

* - For Rear Ported Motors.

DIMENSIONS OF THE ATTACHED COMPONENT

For MSS

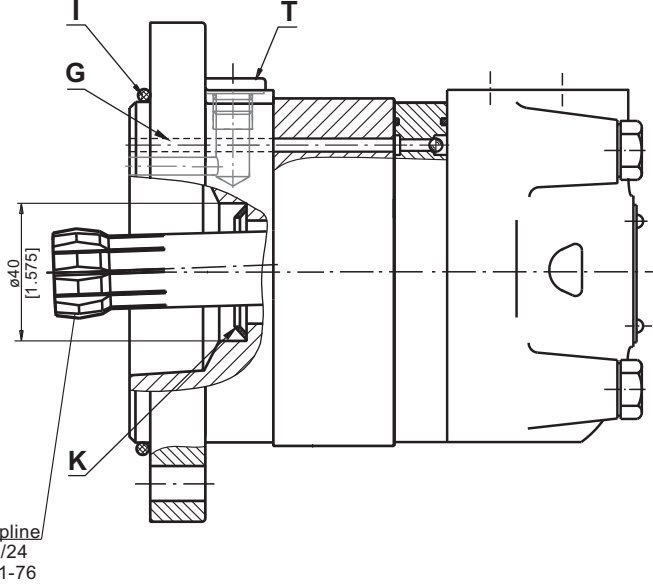
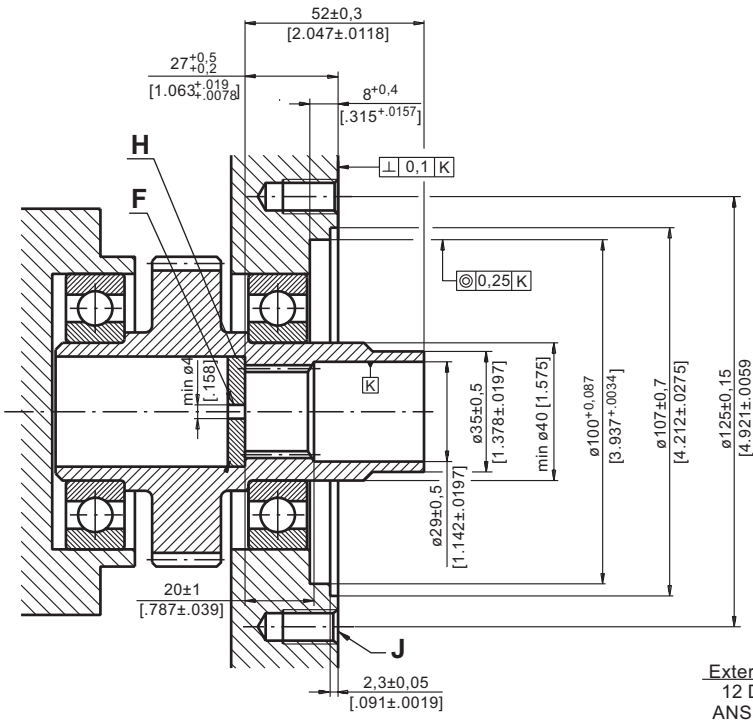

External Spline
12 DP 12/24
ANS B92.1-76

- F : Oil circulation hole
- H : Hardened stop plate
- J : 4xM10 - 16 mm [.63 in] depth, 90°

- G : Internal drain channel
- I : O- Ring 100x3 mm [3.94x.12 in]
- K : Conical seal ring
- T : Drain connection G1/4 or M14x1,5

For MSV

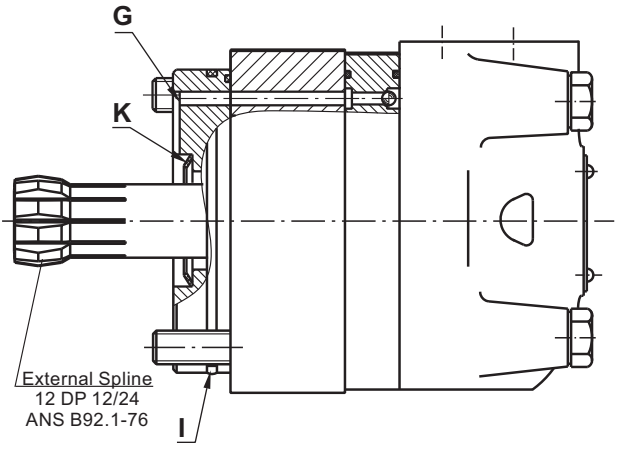
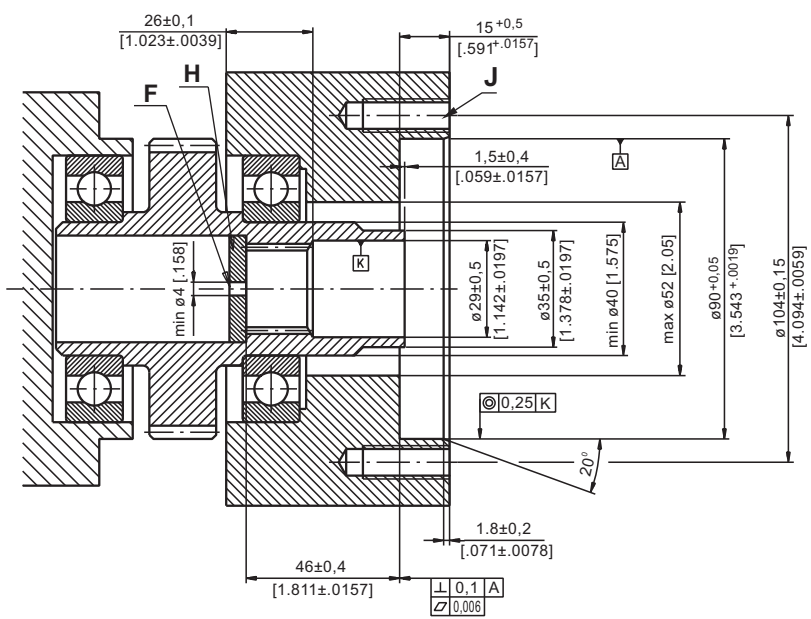

External Spline
12 DP 12/24
ANS B92.1-76

- F : Oil circulation hole
- H : Hardened stop plate
- J : 4xM10 - 26 mm [1.024 in] depth, 90°

- G : Internal drain channel
- I : O- Ring 85x2 mm [3.346x.0787 in]
- K : Conical seal ring



DIMENSIONS OF THE ATTACHED COMPONENT(continued)

For MSU

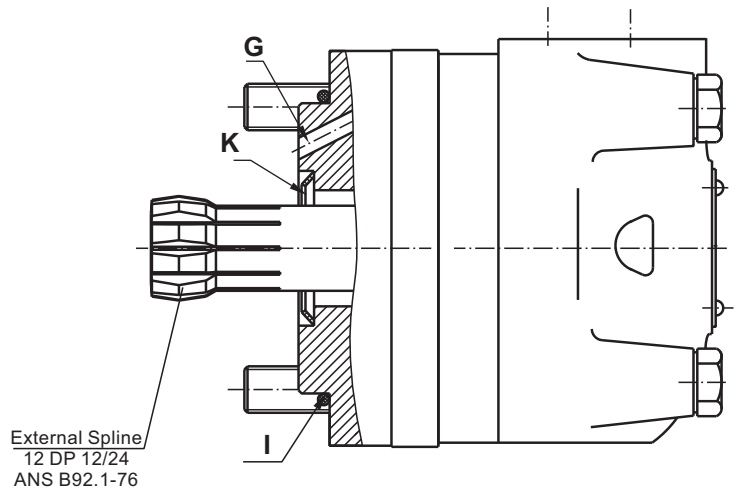
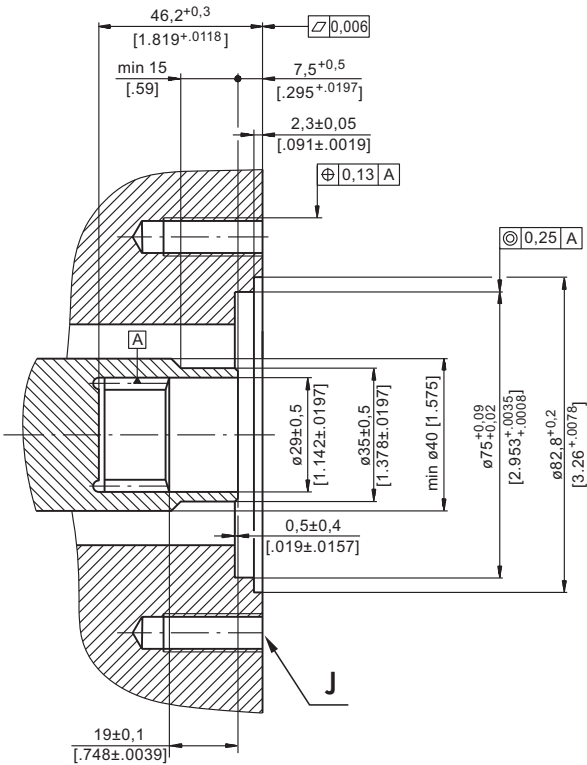

- J** : 4xM10-26 mm [1.024 in] depth, 90°, ø104 [4.094]
- I** : O- Ring 75x3 mm [2.952x.12 in]
- G**: Internal drain channel
- K**: Conical seal ring



DRAIN CONNECTION

The drain line has to be used when pressure in the return line can exceed the permissible pressure. It can be connected:

- For MSS at the drain port of the motor;
- For MSV and MSU at the drain connection of the attached component. The maximum pressure in the drain line is limited by the attached component and its shaft seal.

The drain line must be possible for oil to flow freely between motor and attached component and must be led to the tank. The maximum pressure in the drain line is limited by the attached component and its seal.

INTERNAL SPLINE DATA FOR THE ATTACHED COMPONENT

Standard ANS B92.1-1976, class 5
[m=2.1166; corrected x.m=+0,8]

Flat Root Side Fit	mm	inch
Number of Teeth	z 12	12
Diametral Pitch	DP 12/24	12/24
Pressure Angle	30°	30°
Pitch Dia.	D 25,4	1
Major Dia.	D _{ri} 28,0 _{-0,1}	1.1 ÷ 1.098
Minor Dia.	D _i 23,0 ^{+0,033}	.907 ÷ .905
Space Width [Circular]	L _o 4,308±0,020	.1704 ÷ .1688
Fillet Radius	R 0,2	.008
Max. Measurement between Pins	L 17,62 ^{+0,15}	.699 ÷ .694
Pin Dia.	d 4,835±0,001	.19039÷.19031

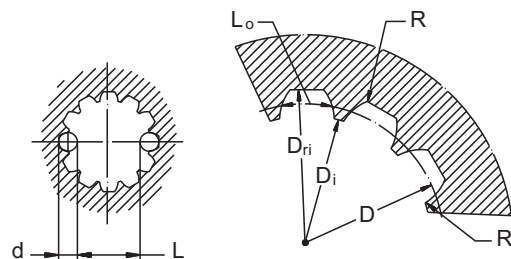

Hardening Specification:
 HV=750±50 on the surface
 HV=560 at 0,7±0,2 mm [.035±.019 in] case depth
 Material: 20 MoCr4 EN 10084 or better

ORDER CODE

	1	2	3	4	5	6	7	8	9
MS									

Pos.1 - Mounting Flange

omit - SAE A-4 mount, four holes

A - SAE A-2 mount, four holes

F - Magneto mount, four holes

Q - Square mount, four holes

B - Motor with drum brake

S - Short motor

V - Very short motor

U - Ultra short motor

W - Wheel mount

Pos.2 - Port type

omit - Side ports

E - Rear ports

Pos.3 - Displacement code

80 - 80,5 cm³/rev [4.91 in³/rev]

100 - 100,0 cm³/rev [6.10 in³/rev]

125 - 125,7 cm³/rev [7.67 in³/rev]

160 - 159,7 cm³/rev [9.74 in³/rev]

200 - 200,0 cm³/rev [12.20 in³/rev]

250 - 250,0 cm³/rev [15.30 in³/rev]

315 - 314,9 cm³/rev [19.20 in³/rev]

400 - 397,0 cm³/rev [24.20 in³/rev]

475 - 474,6 cm³/rev [28.96 in³/rev]

525 - 522,7 cm³/rev [31.88 in³/rev]

565 - 564,9 cm³/rev [34.47 in³/rev]

Pos.4 - Shaft Extensions*

omit - for **B**, **S**, **U** and **V** mounting flange

C - ø32 straight, Parallel key A10x8x45 DIN6885

CO - ø1¼" straight, Parallel key ⁵/₁₆"x⁵/₁₆"x1¼" BS46

K - ø35 tapered 1:10, Parallel key B6x6x20 DIN6885

SL - ø34,85 p.t.o. DIN 9611 Form 1

SH - ø1¼" splined 14T ANS B92.1-1970

SA - 7/8"-13T splined ANS B92.1-1970

CA - ø25 straight, Parallel key A8x7x32 DIN6885

Pos.5 - Shaft Seal Version** (see page 16)

omit - Low pressure seal

U - High pressure seal

Pos.6 - Ports

omit - BSPP (ISO 228)

M - Metric (ISO 262)

Pos.7 - Actuating Direction***

/R - Right

/L - Left

Pos.8 - Additional Options (see page 51)

Pos.9 - Design Series

omit - Factory specified

NOTES:

The following combinations are not allowed: **Q** flange with "**CO**", "**CA**" and "**SA**" shafts.

* The permissible output torque for shafts must not be exceeded!

** Shaft seal is available with the "omit" and "W" mounting flange only!

*** For MSB only!

The hydraulic motors are mangano-phosphatized as standard.

HYDRAULIC MOTORS MT

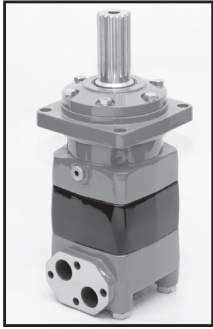

APPLICATION

- ☉ conveyors
- ☉ metal working machines
- ☉ agricultural machines
- ☉ road building machines
- ☉ mining machinery
- ☉ food industries
- ☉ special vehicles
- ☉ plastic and rubber machinery etc.

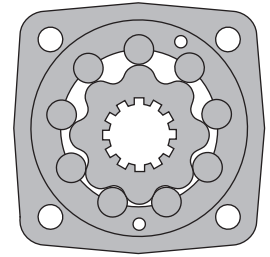
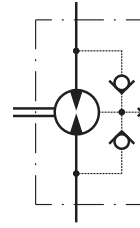

CONTENTS

Specification data	26÷27
Function diagrams	28÷31
Dimensions and mounting	32÷33
Shaft extensions	34
Permissible Shaft Seal pressure	34
Dimensions and mounting- MTS, V	35÷36
Internal Spline data	37
Permissible shaft loads	37
Tacho connection	38
Order code	38

OPTIONS

- ☉ Model - Disc valve, roll-gerotor
- ☉ Flange with wheel mount
- ☉ Short motor
- ☉ Tacho connection
- ☉ Speed sensing
- ☉ Side and rear ports
- ☉ Shafts - straight, splined and tapered
- ☉ Metric and BSPP ports
- ☉ Other special features

GENERAL

Max. Displacement, cm ³ /rev [in ³ /rev]	724,3 [44.2]
Max. Speed, [RPM]	775
Max. Torque, daNm [lb-in]	cont.: 130 [11500] int.: 148 [13100]
Max. Output, kW [HP]	40 [54]
Max. Pressure Drop, bar [PSI]	cont.: 200 [2900] int.: 240 [3480]
Max. Oil Flow, lpm [GPM]	150 [39.6]
Min. Speed, [RPM]	5
Permissible Shaft Loads, daN [lbs]	P _a =1000 [2250]
Pressure fluid	Mineral based- HLP(DIN 51524) or HM(ISO 6743/4)
Temperature range, °C [°F]	-40÷140 [-40÷284]
Optimal Viscosity range, mm ² /s [SUS]	20÷75 [98÷347]
Filtration	ISO code: 18/16/13 According to ISO 4406-1999

Oil flow in drain line

Pressure drop bar [PSI]	Viscosity mm ² /s [SUS]	Oil flow in drain line lpm [GPM]
140 [2030]	20 [98]	2,5 [.660]
	35 [164]	1,5 [.396]
210 [3045]	20 [98]	5 [1.321]
	35 [164]	3 [.793]

Pressure Losses

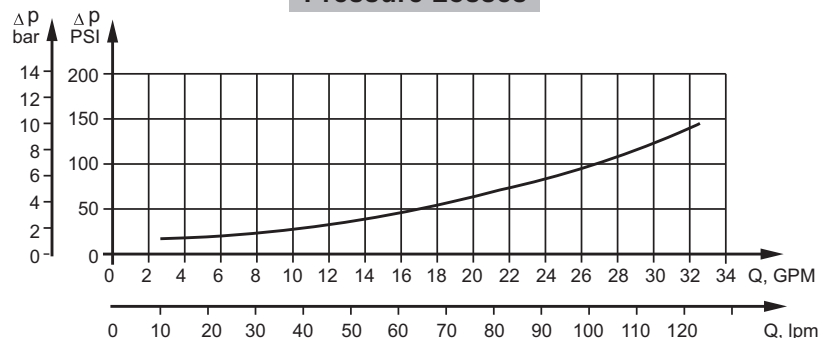

SPECIFICATION DATA

Type		MT 160	MT 200	MT 250	MT 315
Displacement, cm³/rev [in³/rev]		161,1 [9.83]	201,4 [12.29]	251,8 [15.36]	326,3 [19.90]
Max. Speed, [RPM]	Cont.	622	620	496	382
	Int.*	775	752	601	461
Max. Torque daNm [lb-in]	Cont.	47 [4160]	59 [5220]	73 [6460]	95 [8410]
	Int.*	56 [4960]	71 [6285]	88 [7790]	114 [10090]
	Peak**	66 [5840]	82 [7260]	102 [9030]	133 [11770]
Max. Output kW [HP]	Cont.	26,5 [36]	33,5 [45]	33,5 [45]	33,5 [45]
	Int.*	32 [43]	40 [54]	40 [54]	40 [54]
Max. Pressure Drop bar [PSI]	Cont.	200 [2900]	200 [2900]	200 [2900]	200 [2900]
	Int.*	240 [3480]	240 [3480]	240 [3480]	240 [3480]
	Peak**	280 [4050]	280 [4050]	280 [4050]	280 [4050]
Max. Oil Flow lpm [GPM]	Cont.	100 [26]	125 [33]	125 [33]	125 [33]
	Int.*	125 [33]	150 [39.6]	150 [39.6]	150 [39.6]
Max. Inlet Pressure bar [PSI]	Cont.	210 [3050]	210 [3050]	210 [3050]	210 [3050]
	Int.*	250 [3600]	250 [3600]	250 [3600]	250 [3600]
	Peak**	300 [4350]	300 [4350]	300 [4350]	300 [4350]
Max. Return Pressure with Drain Line bar [PSI]	Cont.	140 [2030]	140 [2030]	140 [2030]	140 [2000]
	Int.*	175 [2540]	175 [2540]	175 [2540]	175 [2500]
	Peak**	210 [3050]	210 [3050]	210 [3050]	210 [3000]
Max. Starting Pressure with Unloaded Shaft, bar [PSI]		10 [150]	10 [150]	10 [150]	10 [150]
Min. Starting Torque daNm [lb-in]	At max. press. drop Cont.	34 [3010]	43 [3800]	53 [4690]	74 [6550]
	At max. press. drop Int.*	41 [3630]	52 [4600]	63 [5580]	89 [7880]
Min. Speed***, [RPM]		10	9	8	7
Weight, kg [lb] For Rear Ports +0,450[.992]	MT	20 [44.1]	21,5 [47.4]	21 [46.3]	22 [48.5]
	MTW	22 [48.5]	22,5 [49.6]	23 [50.7]	24 [52.9]
	MTS	15 [33.1]	15,5 [34.2]	16 [35.3]	17 [37.5]
	MTV	11 [24.3]	11,5 [25.4]	12 [26.5]	13 [28.7]

* Intermittent operation: the permissible values may occur for max. 10% of every minute.

** Peak load: the permissible values may occur for max. 1% of every minute.

*** For speeds lower than given, consult factory or your regional manager.

- Intermittent speed and intermittent pressure must not occur simultaneously.
- Recommended filtration is per ISO cleanliness code 20/16. A nominal filtration of 25 micron or better.
- Recommend using a premium quality, anti-wear type mineral based hydraulic oil HLP(DIN51524) or HM (ISO 6743/4).
If using synthetic fluids consult the factory for alternative seal materials.
- Recommended minimum oil viscosity 13 mm²/s [70 SUS] at 50°C [122°F].
- Recommended maximum system operating temperature is 82°C [180°F].
- To assure optimum motor life fill with fluid prior to loading and run at moderate load and speed for 10-15 minutes.

SPECIFICATION DATA (continued)

Type		MT 400	MT 500	MT 630	MT 725
Displacement, cm ³ /rev [in ³ /rev]		410,9 [25.06]	523,6 [31.95]	631,2 [38.52]	724,3 [44.2]
Max. Speed, [RPM]	Cont.	304	238	197	172
	Int.*	368	289	234	209
Max. Torque daNm [lb-in]	Cont.	108 [9560]	122 [10800]	130 [11500]	127 [11240]
	Int.*	126 [11150]	137 [12125]	148 [13100]	147 [13010]
	Peak**	144 [12745]	160 [14160]	176 [15580]	175 [15490]
Max. Output kW [HP]	Cont.	30 [40]	26,5 [36]	24,3 [33]	20,2 [27]
	Int.*	35 [47]	30 [40]	27,5 [37]	26,8 [36]
Max. Pressure Drop bar [PSI]	Cont.	180 [2610]	160 [2320]	140 [2010]	120 [1740]
	Int.*	210 [3050]	180 [2610]	160 [2320]	140 [2010]
	Peak**	240 [3480]	210 [3050]	190 [2760]	165 [2395]
Max. Oil Flow lpm [GPM]	Cont.	125 [33]	125 [33]	125 [33]	125 [33]
	Int.*	150 [39.6]	150 [39.6]	150 [39.6]	150 [39.6]
Max. Inlet Pressure bar [PSI]	Cont.	210 [3050]	210 [3050]	210 [3600]	210 [3050]
	Int.*	250 [3600]	250 [3600]	250 [4350]	250 [3600]
	Peak**	300 [4350]	300 [4350]	300 [2000]	300 [4350]
Max. Return Pressure with Drain Line bar [PSI]	Cont.	140 [2000]	140 [2000]	140 [2500]	140 [2000]
	Int.*	175 [2500]	175 [2500]	175 [2500]	175 [2500]
	Peak**	210 [3000]	210 [3000]	210 [3000]	210 [3000]
Max. Starting Pressure with Unloaded Shaft, bar [PSI]		10 [150]	10 [150]	10 [150]	10 [150]
Min. Starting Torque daNm [lb-in]	At max. press. drop Cont.	84 [7435]	95 [8410]	95 [8410]	95 [8410]
	At max. press. drop Int.*	97 [8585]	106 [9380]	110 [9740]	115 [10180]
Min. Speed***, [RPM]		6	5	5	5
Weight, kg [lb] For Rear Ports +0,450 [.992]	MT	23 [50.7]	24 [52.9]	23,5 [51.8]	24,5 [54.0]
	MTW	25 [55.1]	26 [57.3]	25,5 [56.2]	26,5 [58.4]
	MTS	18 [39.7]	19 [41.9]	18,5 [40.8]	19,5 [43.0]
	MTV	14 [30.9]	15 [33.1]	14,5 [32.0]	15,5 [34.2]

* Intermittent operation: the permissible values may occur for max. 10% of every minute.

** Peak load: the permissible values may occur for max. 1% of every minute.

*** For speeds lower than given, consult factory or your regional manager.

- Intermittent speed and intermittent pressure must not occur simultaneously.
- Recommended filtration is per ISO cleanliness code 20/16. A nominal filtration of 25 micron or better.
- Recommend using a premium quality, anti-wear type mineral based hydraulic oil HLP(DIN51524) or HM (ISO 6743/4).
If using synthetic fluids consult the factory for alternative seal materials.
- Recommended minimum oil viscosity 13 mm²/s [70 SUS] at 50°C [122°F].
- Recommended maximum system operating temperature is 82°C [180°F].
- To assure optimum motor life fill with fluid prior to loading and run at moderate load and speed for 10-15 minutes.

FUNCTION DIAGRAMS

MT 160

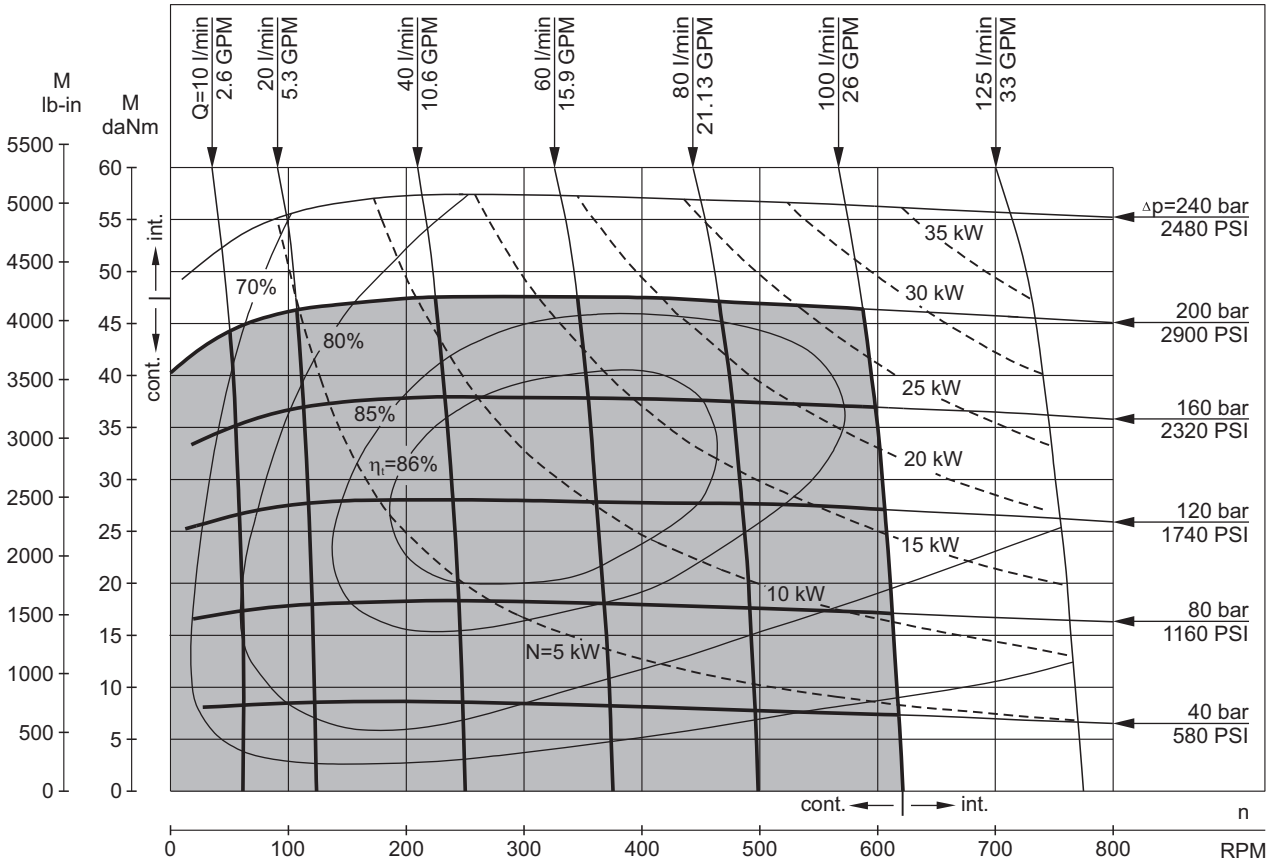

MT 200

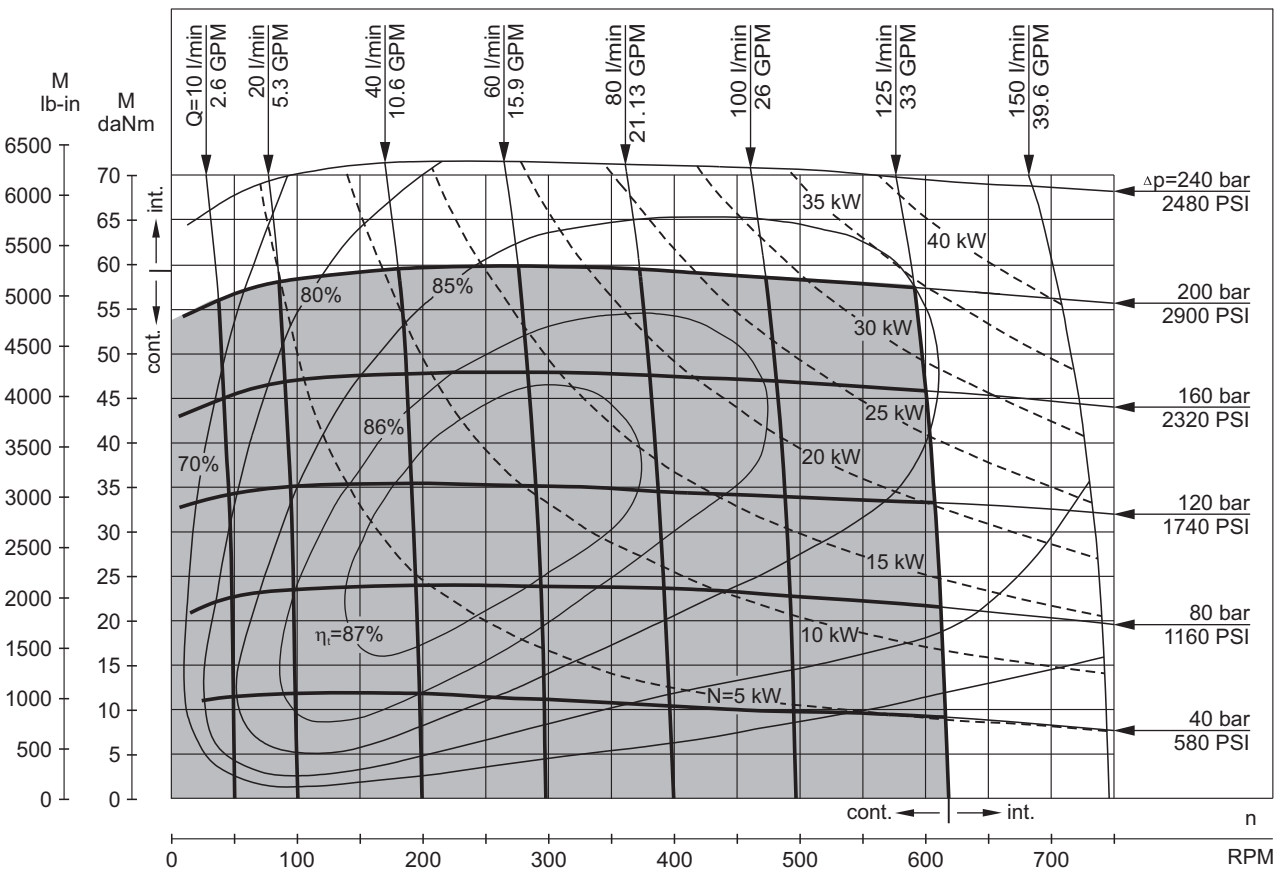

The function diagrams data is for average performance of randomly selected motors at back pressure 5±10 bar [72.5 PSI±145 PSI] and oil with viscosity of 32 mm²/s [150 SUS] at 50°C [122°F].

FUNCTION DIAGRAMS

MT 250

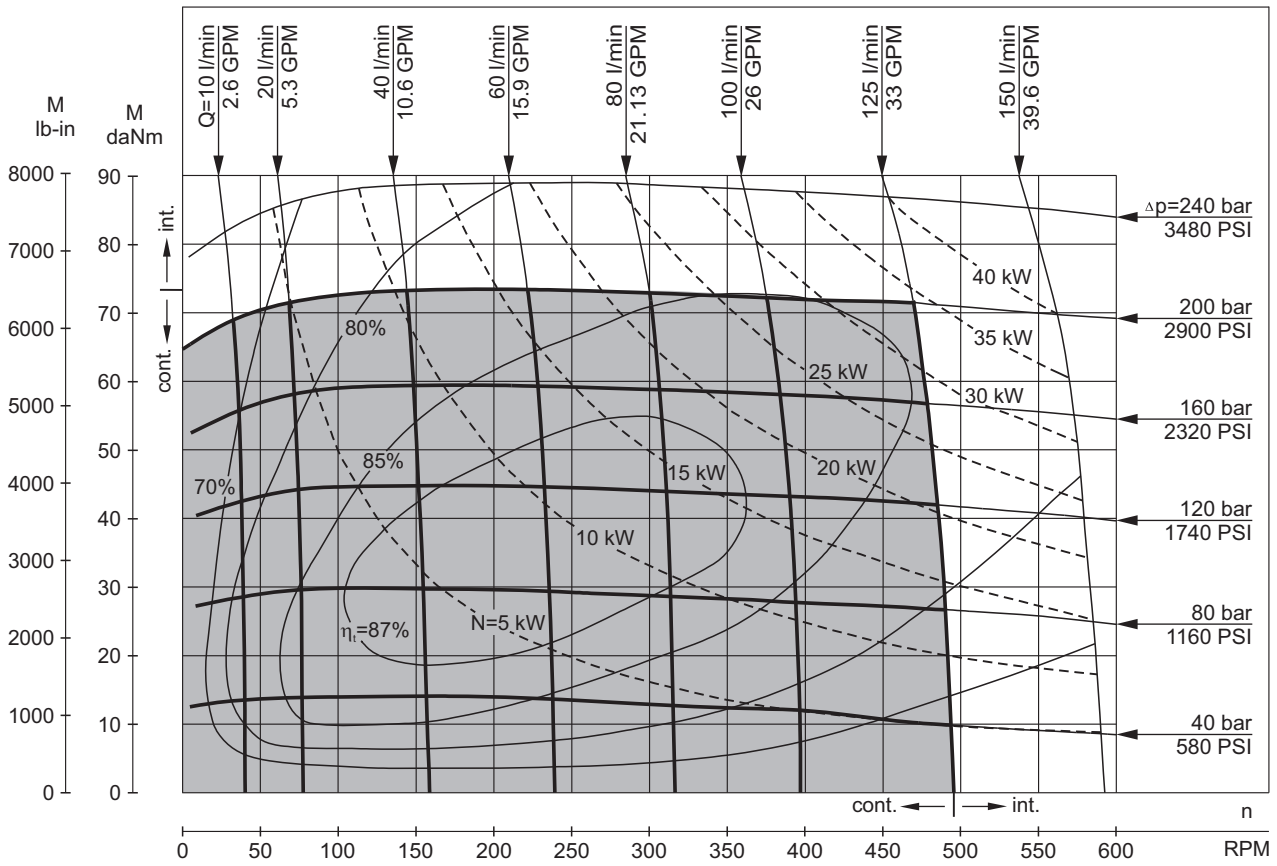

MT 315

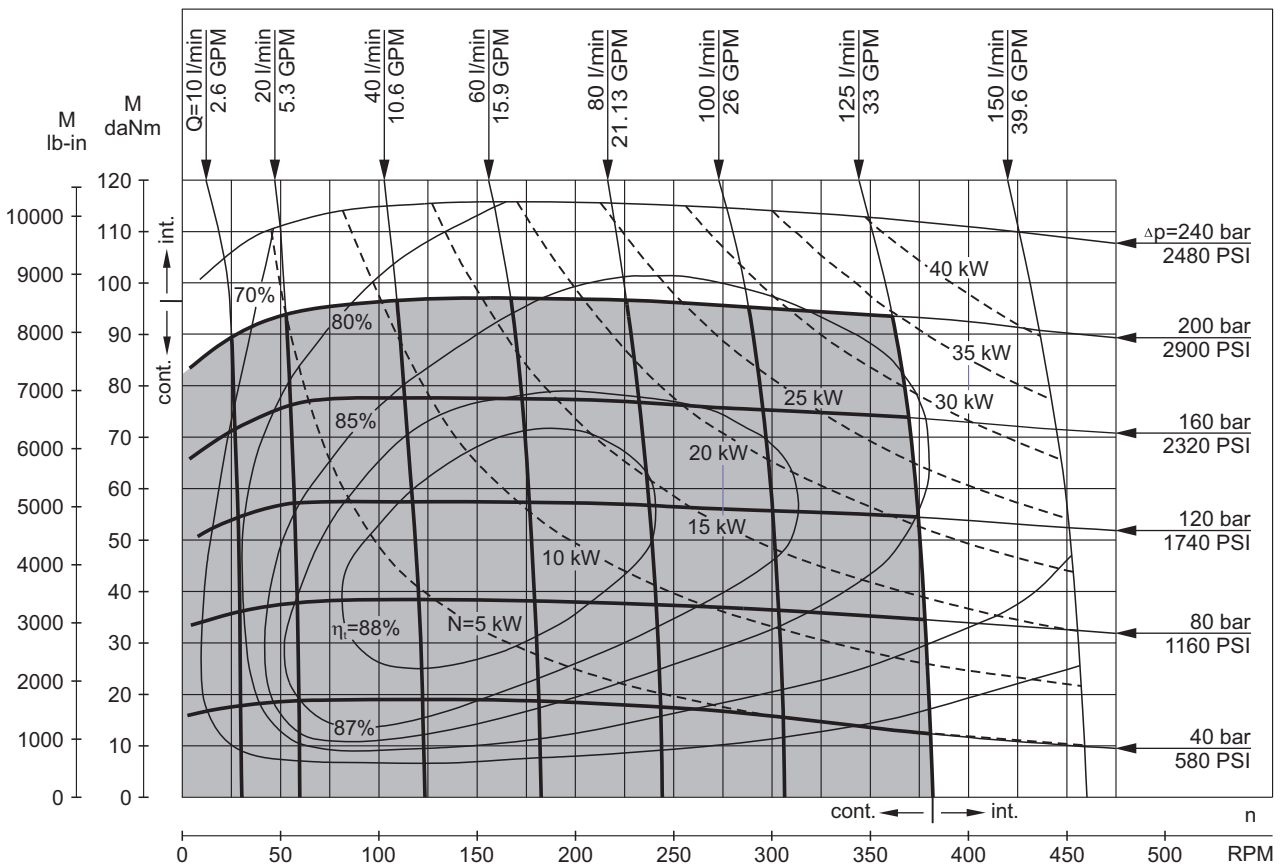

The function diagrams data is for average performance of randomly selected motors at back pressure 5±10 bar [72.5 PSI±145 PSI] and oil with viscosity of 32 mm²/s [150 SUS] at 50°C [122°F].

FUNCTION DIAGRAMS

MT 400

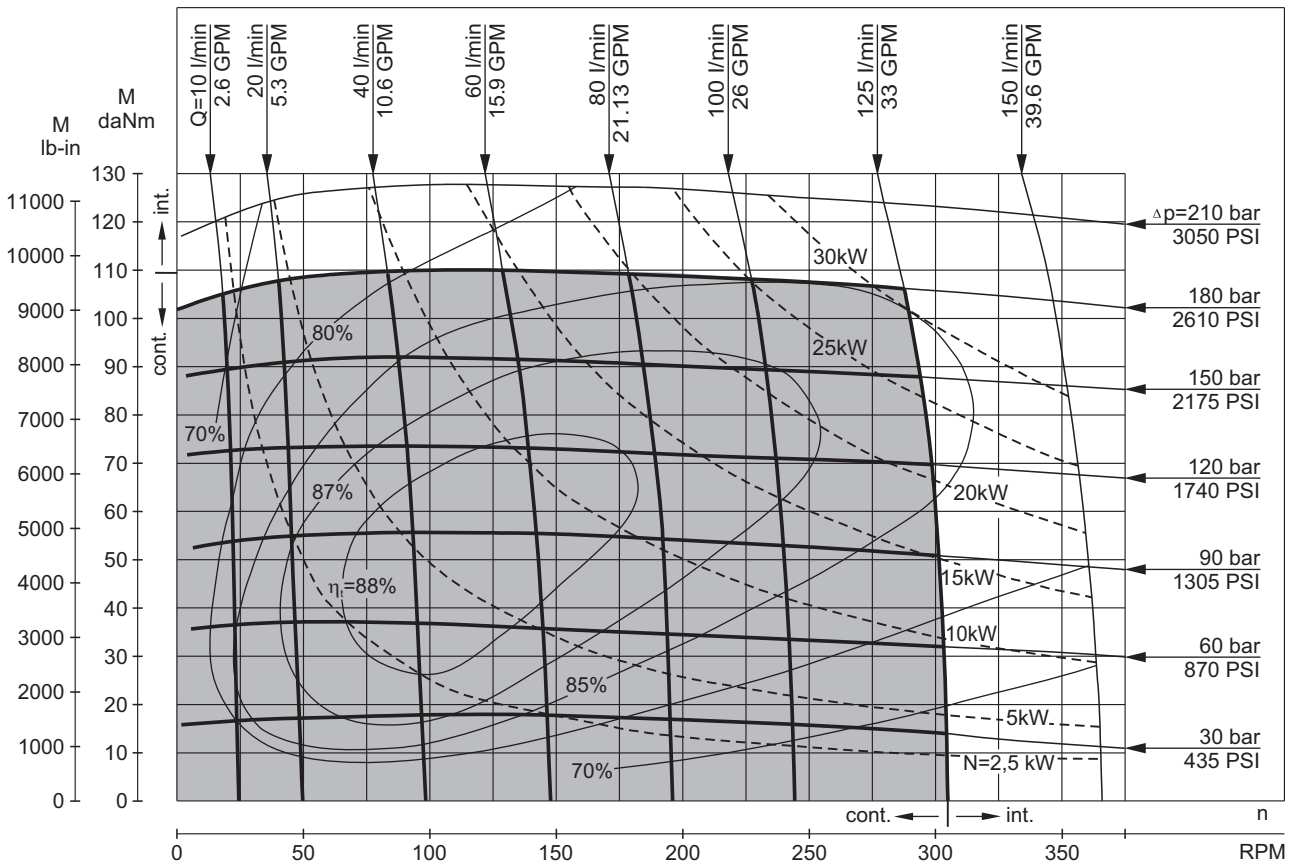

MT 500

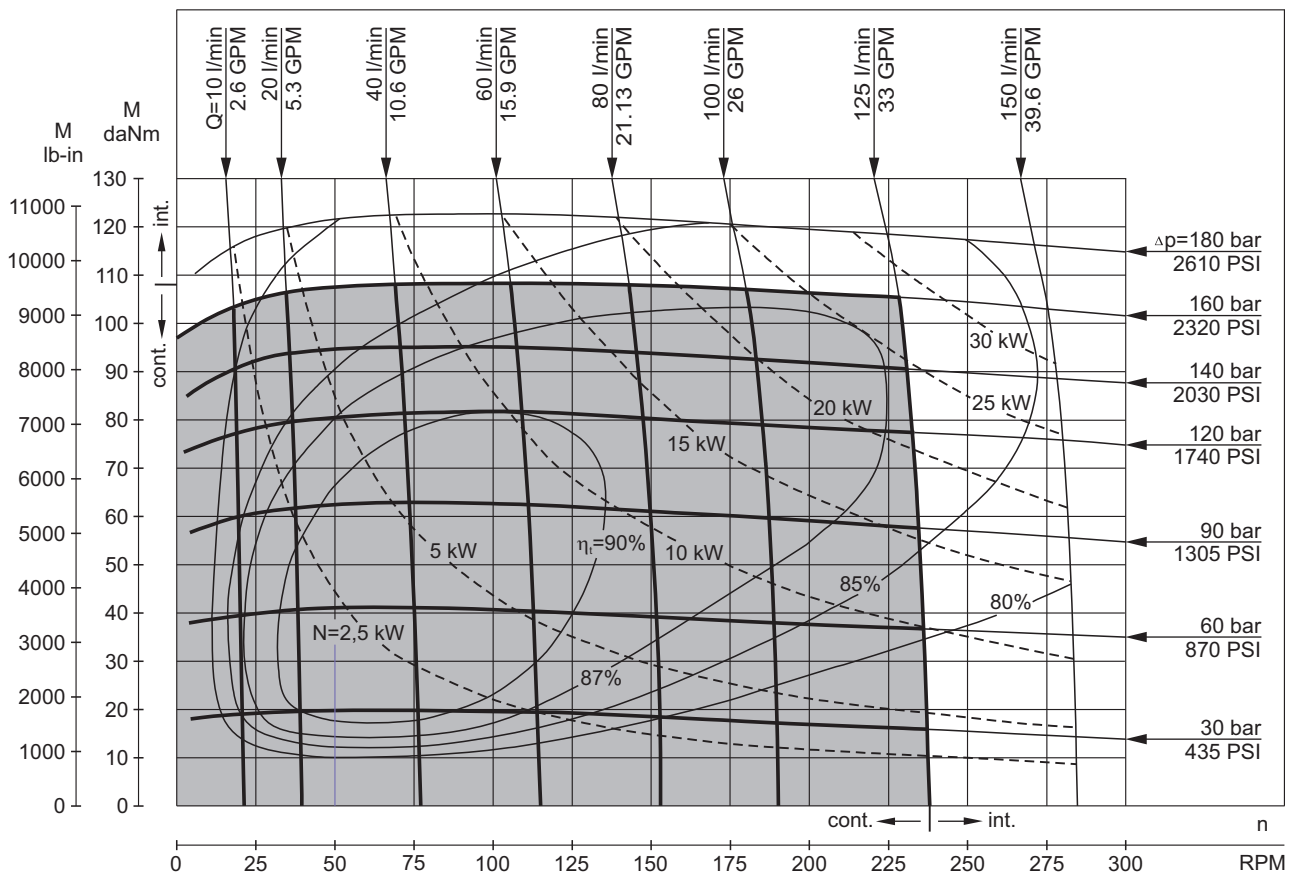

The function diagrams data is for average performance of randomly selected motors at back pressure 5±10 bar [72.5 PSI±145 PSI] and oil with viscosity of 32 mm²/s [150 SUS] at 50°C [122°F].

MT 630

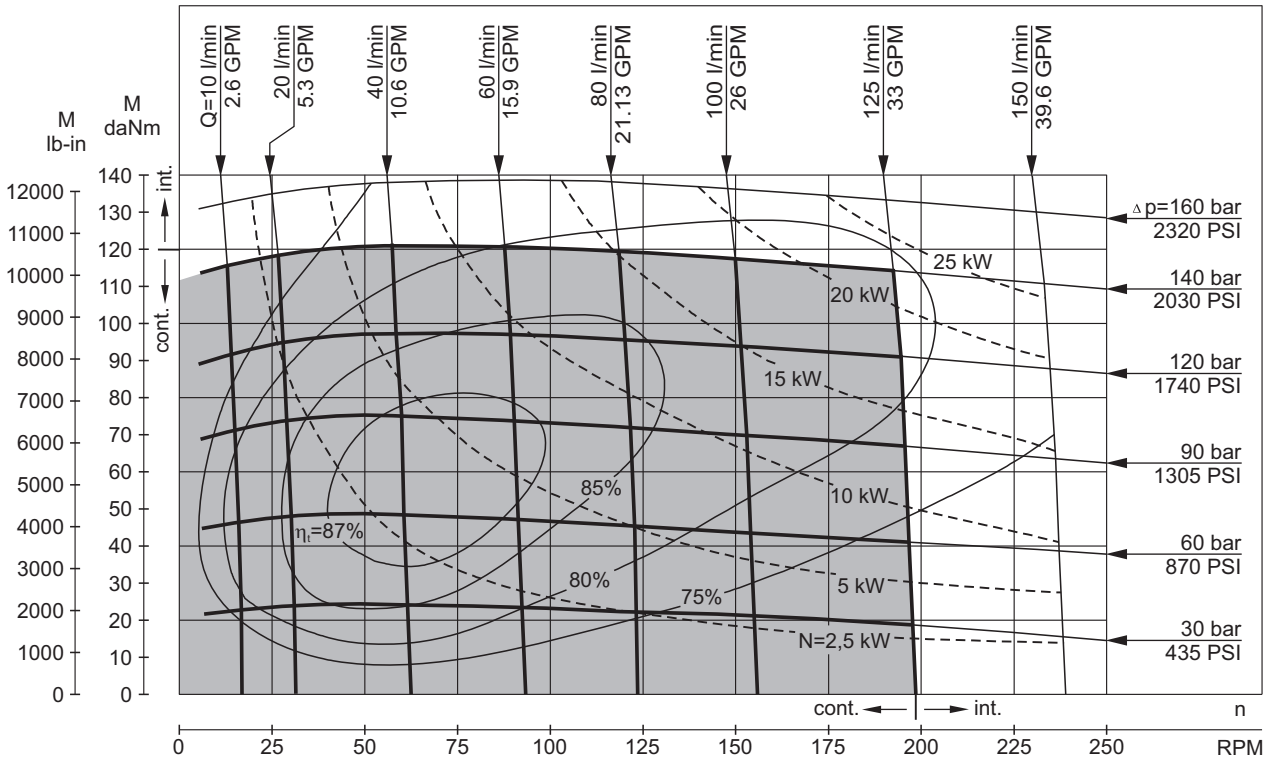

MT 725

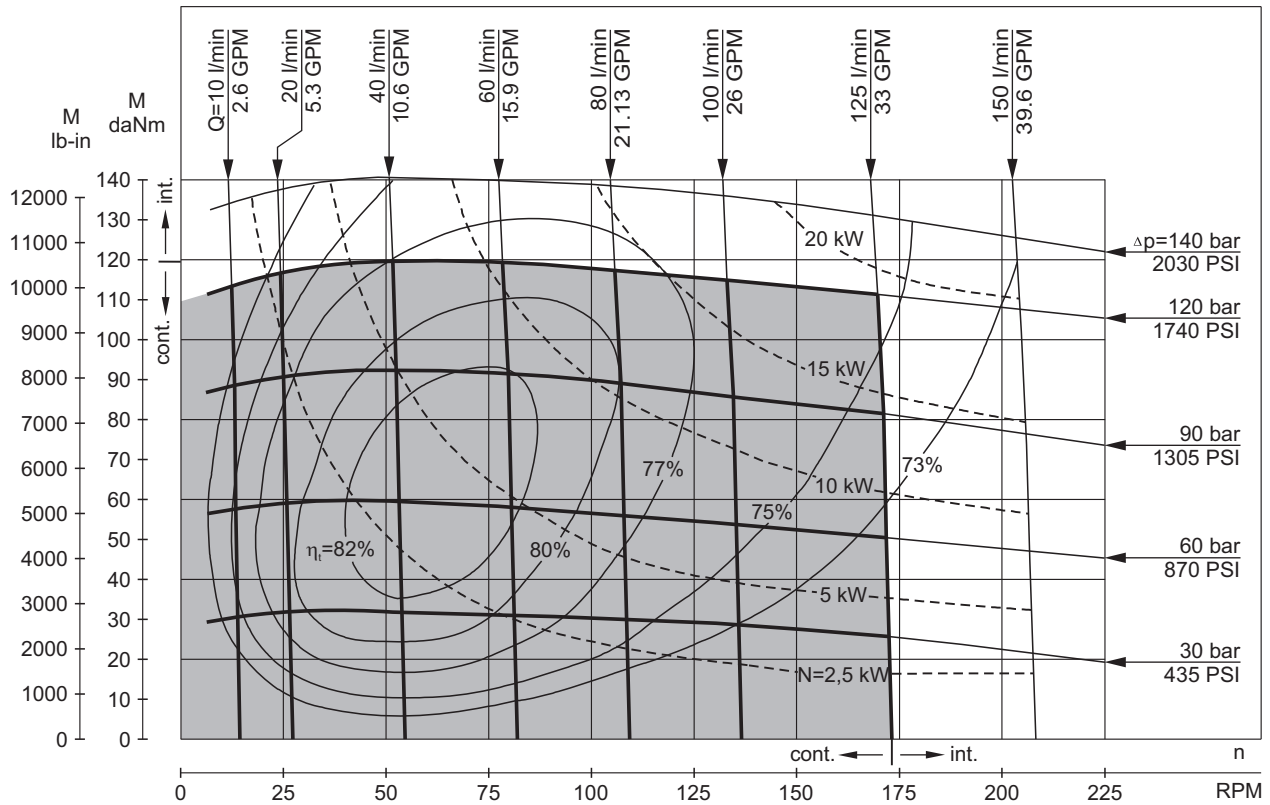

The function diagrams data is for average performance of randomly selected motors at back pressure 5 ± 10 bar [72.5 PSI \pm 145 PSI] and oil with viscosity of 32 mm²/s [150 SUS] at 50°C [122°F].

DIMENSIONS and MOUNTING DATA

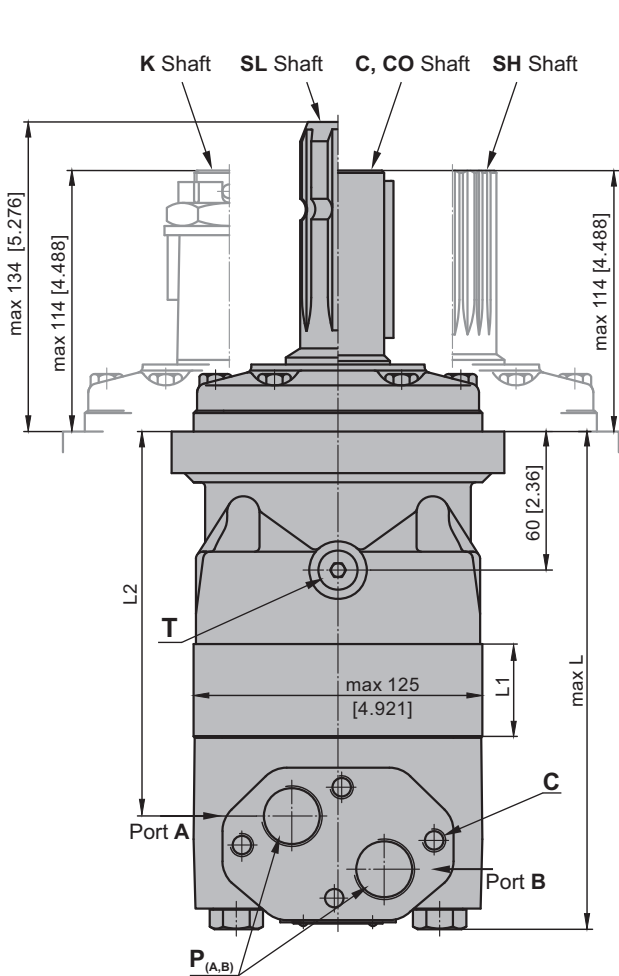

Shaft Dim.
See Page 34

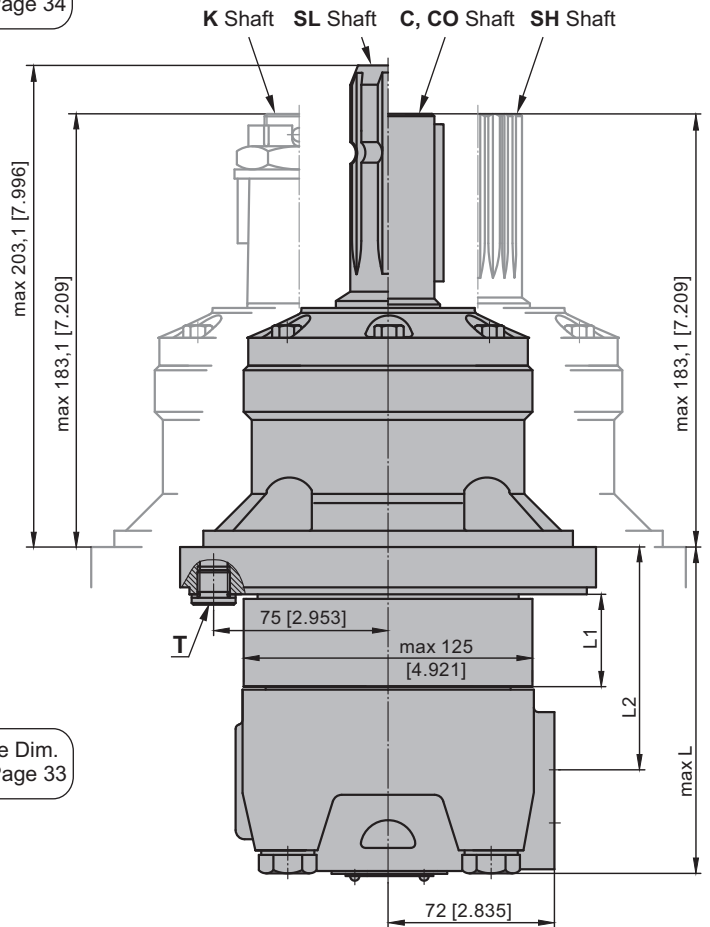

Flange Dim.
See Page 33

Port Dim.
See Page 33

E Rear ports

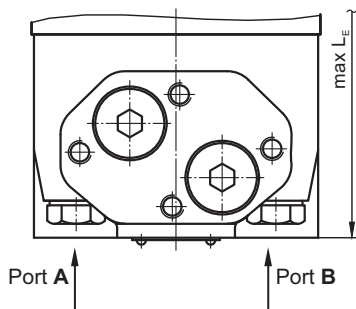

- C** : 4xM10-10 mm [.39 in] depth
- P_(A,B)** : 2xG3/4 or 2xM27x2-17 mm [.67 in] depth
- T** : G 1/4 or M14x1,5 - 12 mm [.47 in] depth (plugged)

Standard Rotation

Viewed from Shaft End
Port A Pressurized - **CW**
Port B Pressurized - **CCW**

Reverse Rotation

Viewed from Shaft End
Port A Pressurized - **CCW**
Port B Pressurized - **CW**

Type	L, mm [in]	L ₂ , mm [in]	**L _E , mm [in]	Type	L, mm [in]	L ₂ , mm [in]	**L _E , mm [in]	*L ₁ , mm [in]
MT 160	193,1 [7.60]	143,5 [5.65]	203,1 [8.00]	MTW 160	124,1 [4.89]	74,3 [2.93]	134,1 [5.28]	16,5 [.65]
MT 200	198,1 [7.80]	148,5 [5.85]	208,1 [8.19]	MTW 200	129,1 [5.08]	79,3 [3.12]	139,1 [5.48]	21,5 [.85]
MT 250	204,4 [8.05]	154,8 [6.09]	214,4 [8.44]	MTW 250	135,4 [5.33]	85,6 [3.37]	145,4 [5.72]	27,8 [1.09]
MT 315	213,6 [8.41]	164,0 [6.46]	223,6 [8.80]	MTW 315	144,6 [5.69]	94,8 [3.73]	154,6 [6.09]	37,0 [1.46]
MT 400	224,1 [8.82]	174,5 [6.87]	234,1 [9.22]	MTW 400	155,1 [6.11]	105,3 [4.15]	165,1 [6.50]	47,5 [1.87]
MT 500	238,1 [9.37]	188,5 [7.42]	248,1 [9.77]	MTW 500	169,1 [6.66]	119,3 [4.70]	179,1 [7.05]	61,5 [2.42]
MT 630	234,1 [9.22]	184,5 [7.26]	244,1 [9.61]	MTW 630	165,1 [6.50]	115,3 [4.54]	175,1 [6.89]	57,5 [2.26]
MT 725	243,1 [9.57]	193,5 [7.62]	253,1 [9.96]	MTW 725	174,1 [6.85]	124,3 [4.89]	184,1 [7.25]	66,5 [2.62]

* - The width of the roll-gerotor is 3,5 mm [.138 in] greater than L₁.
 ** - For Rear Ported Motors.

MOUNTING

Square Mount (4 Holes)

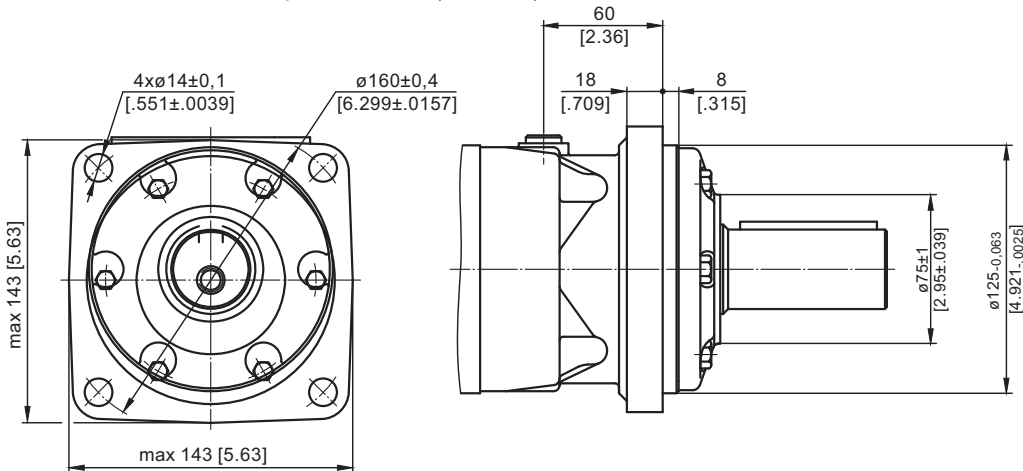

W Wheel Mount

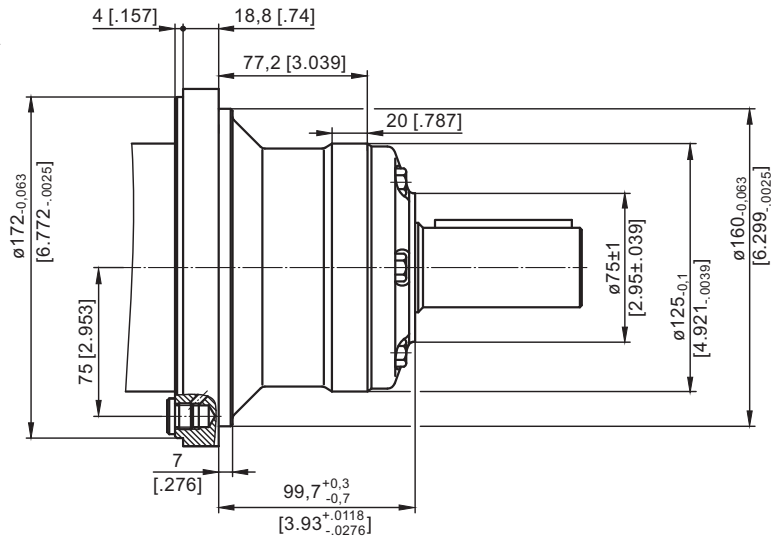
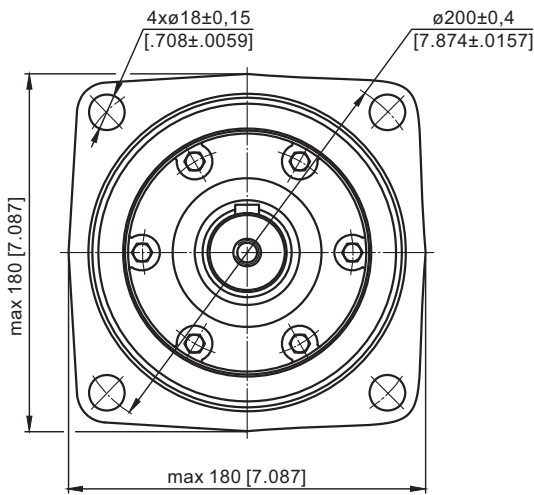

PORTS

Side Ports

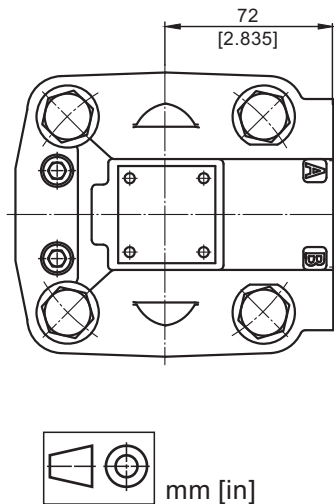
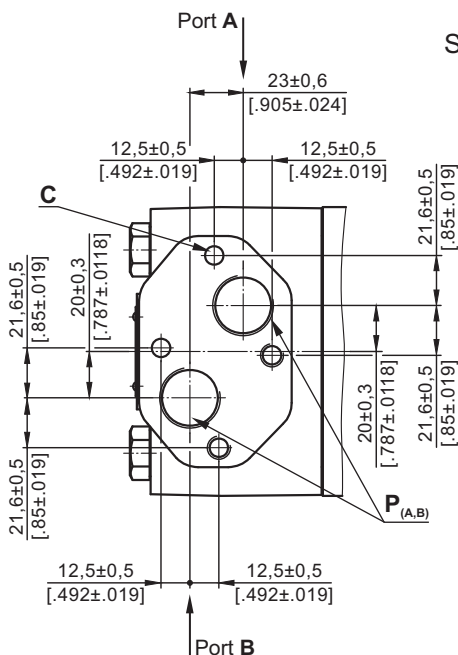

E Rear Ports

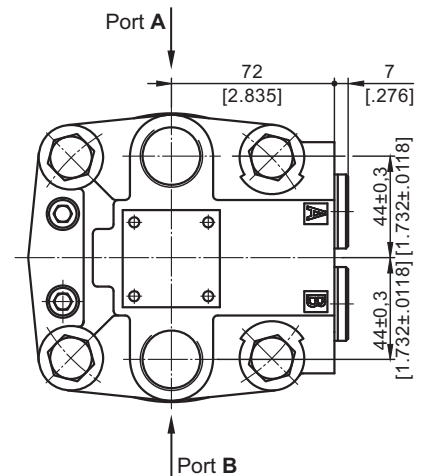

Standard Rotation
Viewed from Shaft End
Port A Pressurized - **CW**
Port B Pressurized - **CCW**

Reverse Rotation
Viewed from Shaft End
Port A Pressurized - **CCW**
Port B Pressurized - **CW**

C : 4xM10-10 mm [0.39 in] depth
P_(A,B) : 2xG3/4 or 2xM27x2-17 mm [0.67 in] depth
T : G 1/4 or M14x1,5 - 12 mm [0.47 in] depth (plugged)

SHAFT EXTENSIONS

C - $\varnothing 40$ straight, Parallel key A12x8x70 DIN 6885
Max. Torque 132,8 daNm [11755 lb-in]

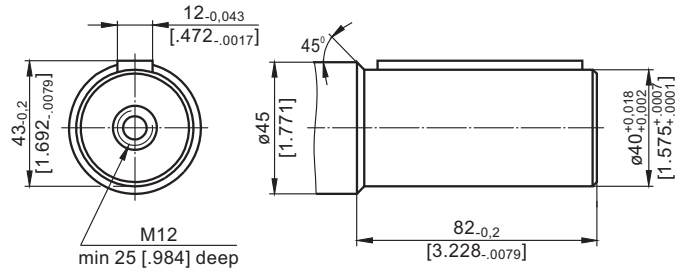

K - tapered 1:10, Parallel key B12x8x28 DIN 6885
Max. Torque 210,7 daNm [18650 lb-in]

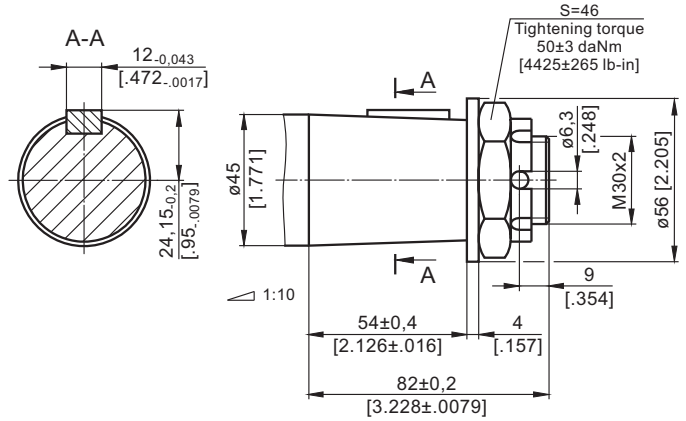

CO - $\varnothing 1\frac{1}{2}$ " straight, Parallel key $\frac{3}{8}$ "x $\frac{3}{8}$ "x $\frac{1}{4}$ " BS46
Max. Torque 132,8 daNm [11755 lb-in]

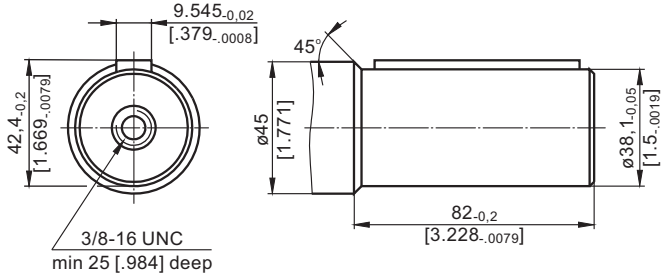

SH - $\varnothing 1\frac{1}{2}$ " splined 17T, DP 12/24 ANSI B92.1-1976
Max. Torque 132,8 daNm [11755 lb-in]

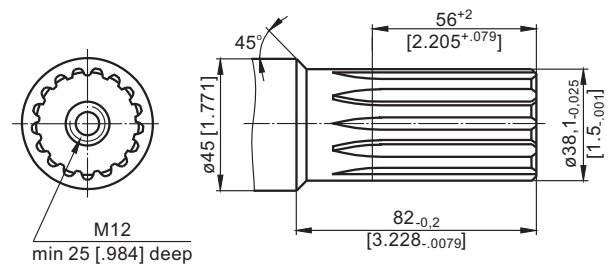

SL - $\varnothing 34,85$ p.t.o. DIN 9611 Form 1
Max. Torque 77 daNm [6815 lb-in]

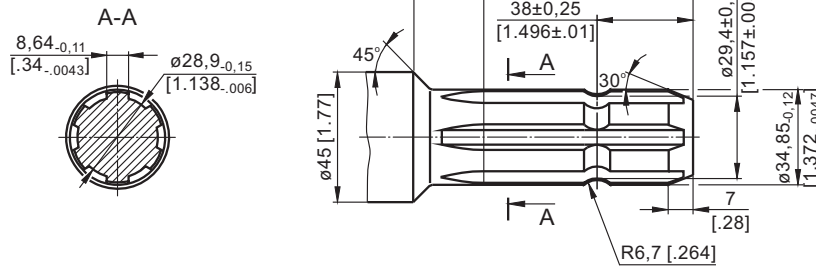

MAX. PERMISSIBLE SHAFT SEAL PRESSURE

Max. return pressure without drain line or
max. pressure in the drain line

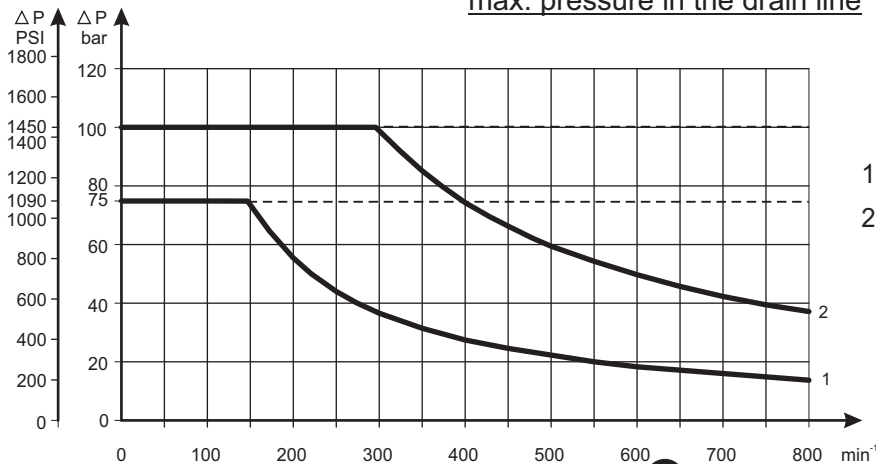

1: Drawing for Standard Shaft Seal
2: Drawing for High Pressure Seal ("U" Seal)

— - continuous operations
- - - - intermittent operations

S Short Mount

V Very Short Mount

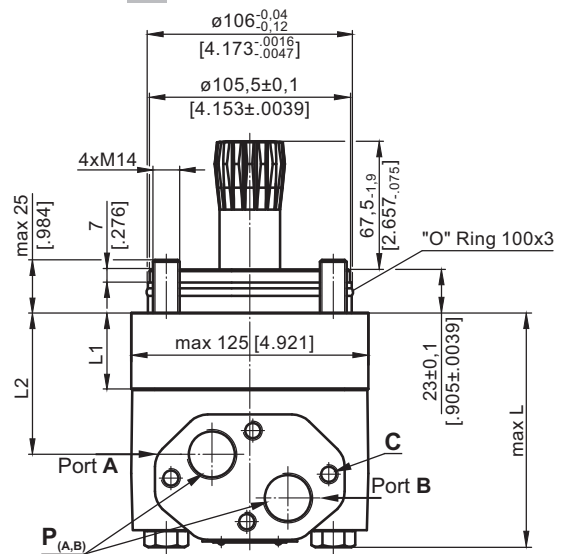
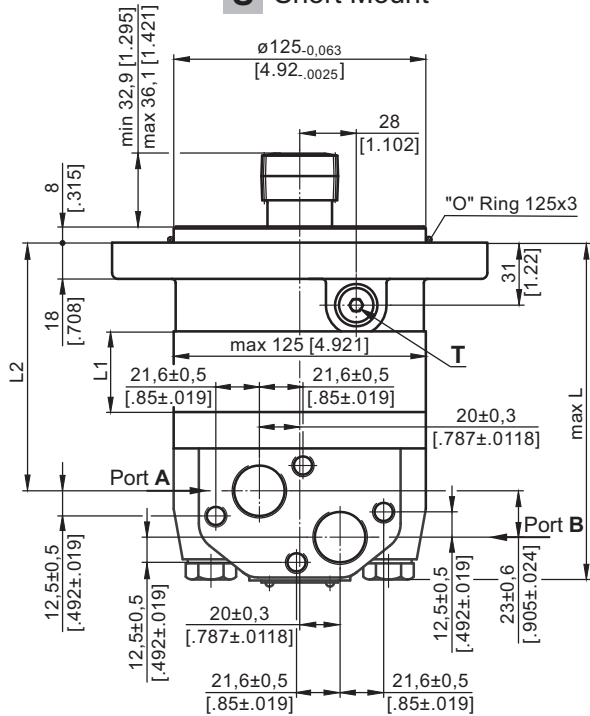

Port Dim.
See Page 33

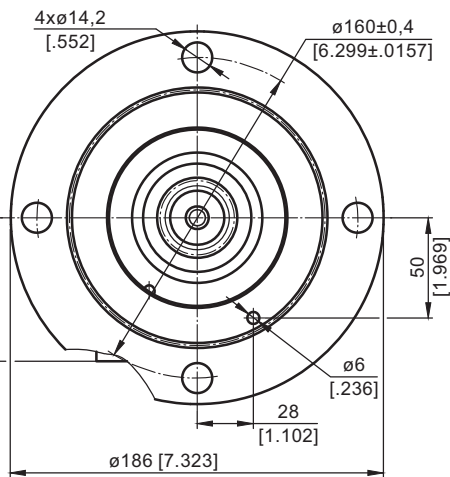
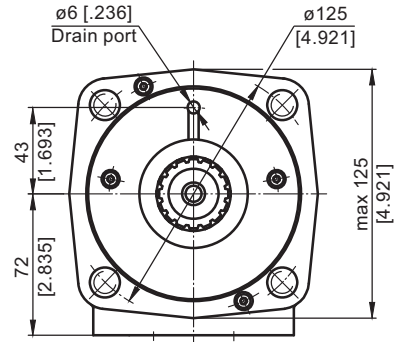

E Rear ports

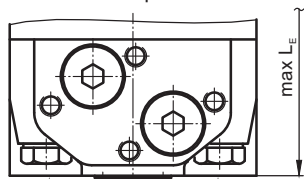

Port A Port B

- C:** 4xM10-10 mm [.39 in] depth
- P_(A,B):** 2xG3/4 or 2xM27x2-17 mm [.67 in] depth
- T:** G 1/4 or M14x1,5 - 12 mm [.47 in] depth (plugged)

Standard Rotation
Viewed from Shaft End
Port A Pressurized - **CW**
Port B Pressurized - **CCW**

Reverse Rotation
Viewed from Shaft End
Port A Pressurized - **CCW**
Port B Pressurized - **CW**

Type	L, mm [in]	L2, mm [in]	**LE, mm [in]	*L1, mm [in]	Type	L, mm [in]	L2, mm [in]	**LE, mm [in]	*L1, mm [in]
MTS 160	150 [5.90]	103,5 [4.07]	155 [6.10]	20,0 [.79]	MTV 160	100,8 [3.97]	51,5 [2.02]	110,8 [4.36]	16,5 [.65]
MTS 200	155 [6.10]	108,5 [4.27]	160 [6.30]	25,0 [.98]	MTV 200	105,8 [4.17]	56,5 [2.22]	115,8 [4.56]	21,5 [.85]
MTS 250	161 [6.34]	114,8 [4.52]	167 [6.57]	31,3 [1.23]	MTV 250	112,1 [4.41]	62,8 [2.47]	122,1 [4.81]	27,8 [1.09]
MTS 315	170 [6.69]	124,0 [4.88]	176 [6.93]	40,5 [1.59]	MTV 315	121,3 [4.76]	72,0 [2.83]	131,3 [5.17]	37,0 [1.46]
MTS 400	181 [7.13]	134,5 [5.30]	186 [7.32]	51,0 [2.01]	MTV 400	131,8 [5.19]	82,5 [3.25]	141,8 [5.58]	47,5 [1.87]
MTS 500	195 [7.68]	148,5 [5.85]	200 [7.87]	65,0 [2.56]	MTV 500	145,8 [5.74]	96,5 [3.80]	155,8 [6.13]	61,5 [2.42]
MTS 630	191 [7.52]	144,5 [5.69]	196 [7.72]	61,0 [2.40]	MTV 630	141,8 [5.58]	92,5 [3.64]	151,8 [5.98]	57,5 [2.26]
MTS 725	200 [7.87]	153,5 [6.04]	205 [8.07]	70,0 [2.76]	MTV 725	150,8 [5.94]	101,5 [4.00]	160,8 [6.33]	66,5 [2.62]

* - The width of the roll-gerotor is 3,5 mm [.138 in] greater than L₁.
** - For Rear Ported Motors.

DIMENSIONS of the ATTACHED COMPONENT

MTS

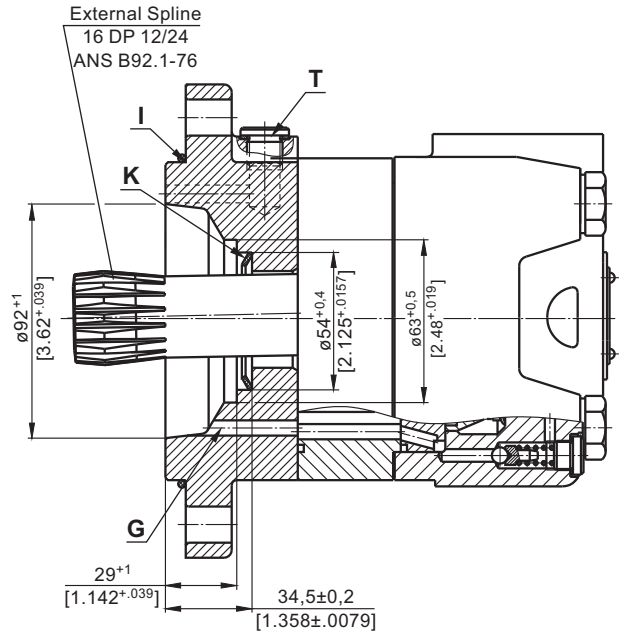
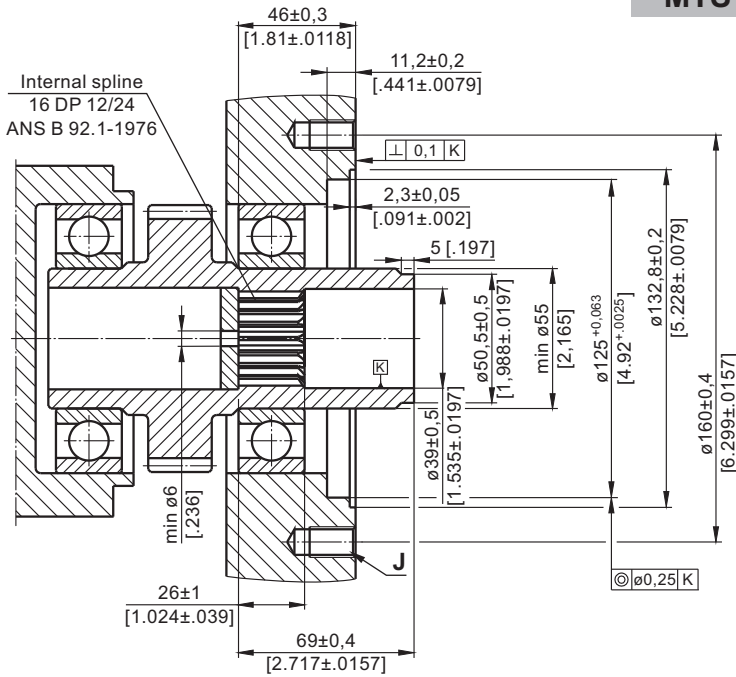

- F** : Oil circulation hole
- G** : Internal drain channel
- H** : Hardened stop plate

- I** : O- Ring 125x3 mm [4.921x.118 in]
- J** : 4xM12-18 mm [.71 in] depth, 90°
- K** : Conical seal ring
- T** : Drain connection G1/4 or M14x1,5

MTV

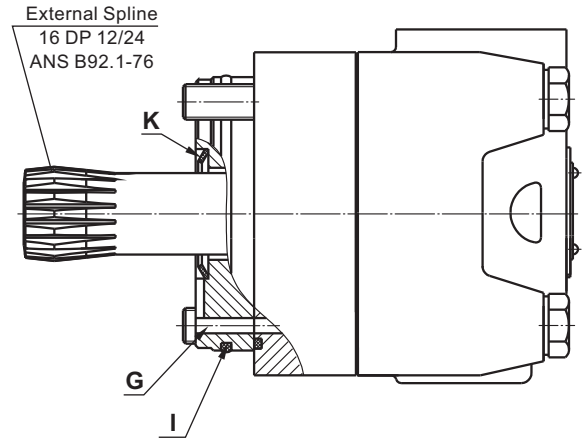
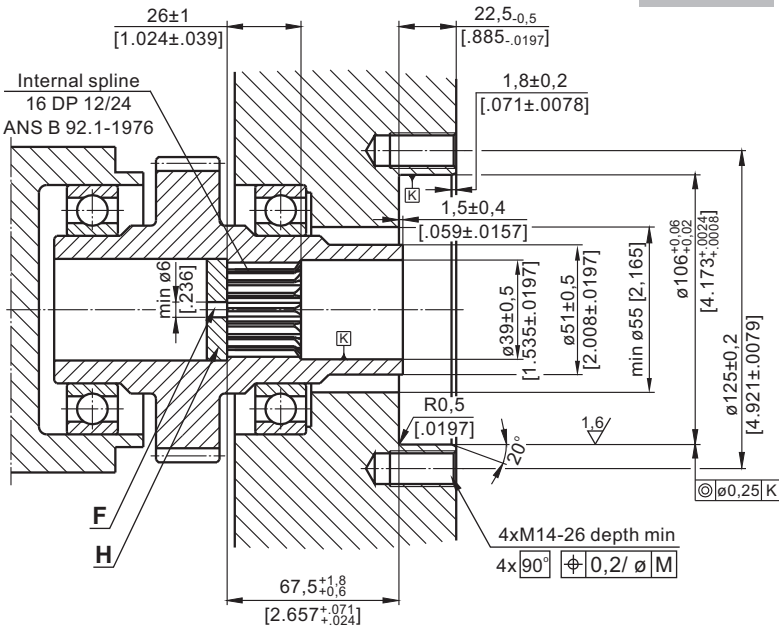

- F** : Oil circulation hole
- G** : Internal drain channel

- H** : Hardened stop plate
- I** : O- Ring 100x3 mm [3.94x.12 in]
- K** : Conical seal ring

DRAIN CONNECTION

The drain line has to be used when pressure in the return line can exceed the permissible pressure. It can be connected:

- For MTS at the drain port of the motor;
- For MTV at the drain connection of the attached component. The maximum pressure in the drain line is limited by the attached component and its shaft seal.

The drain line must be possible for oil to flow freely between motor and attached component and must be led to the tank. The maximum pressure in the drain line is limited by the attached component and its seal.

INTERNAL SPLINE DATA for the ATTACHED COMPONENT

Standard ANS B92.1-1976, class 5
[$m=2.1166$; corrected $x.m=1$]

Flat Root Side Fit		mm	inch
Number of Teeth	z	16	16
Diametral Pitch	DP	12/24	12/24
Pressure Angle		30°	30°
Pitch Dia.	D	33,8656	1.3333
Major Dia.	D _{ri}	38,4 ^{+0,4}	1.5118±1.5275
Minor Dia.	D _i	32,15 ^{+0,04}	1.2657±1.2673
Space Width [Circular]	L _o	4,516±0,037	.1763±.1791
Fillet Radius	R	0,5	.02
Max. Measurement between Pins	L	26,9 ^{+0,10}	1.063±1.059
Pin Dia.	d	4,835±0,001	.19026±.19034

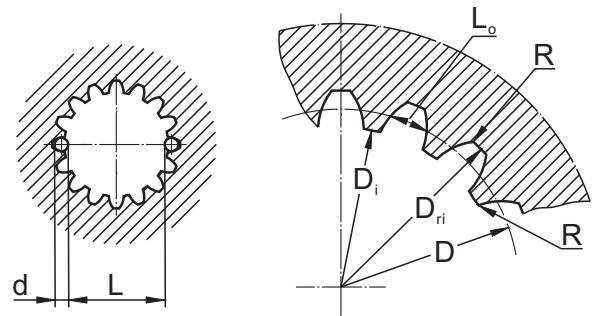

Hardening Specification:
 HV=750±50 on the surface.
 HV=560 at 0,7±0,2 mm [.035±.019in] case depth
 Material: 20 MoCr4 EN 10084 or SAE8620.

PERMISSIBLE SHAFT LOADS

The output shaft runs in tapered bearings that permit high axial and radial forces. The permissible radial load on the shaft is shown for an axial load of 0 N as function of the distance from the mounting flange to the point of load application. The curves apply to a B10 bearing life of 2000 hours at 100 RPM .

Curve "1" shows max. radial shaft load. Any shaft load exceeding the values shown by the curve will seriously reduce motor life.

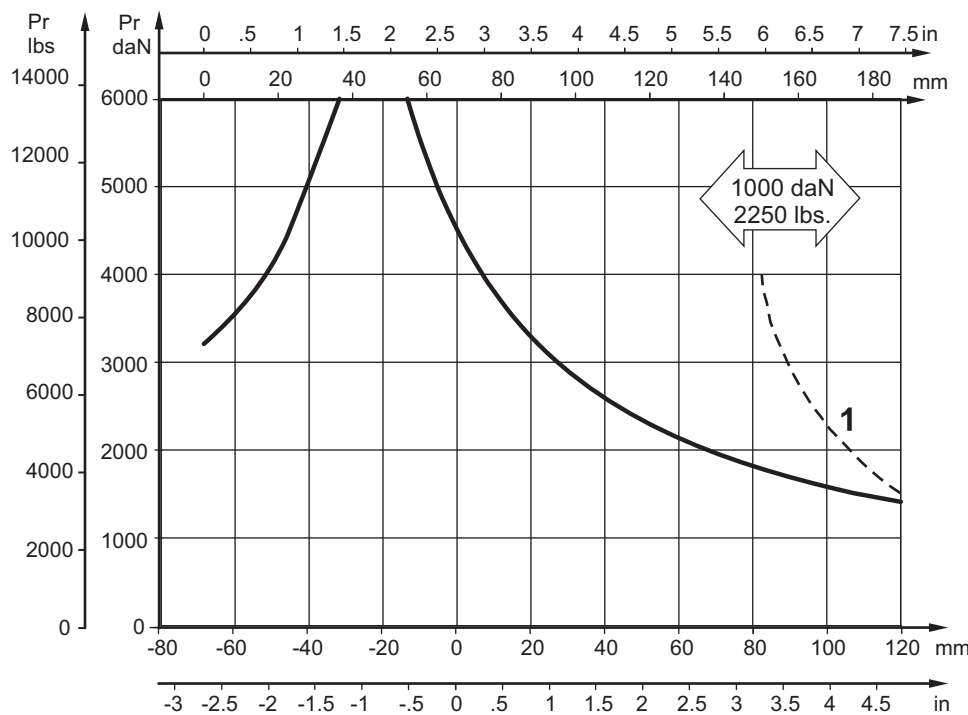

Mounting Flange:

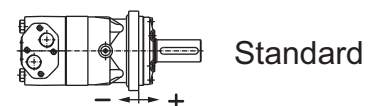

MOTORS with TACHO CONNECTION

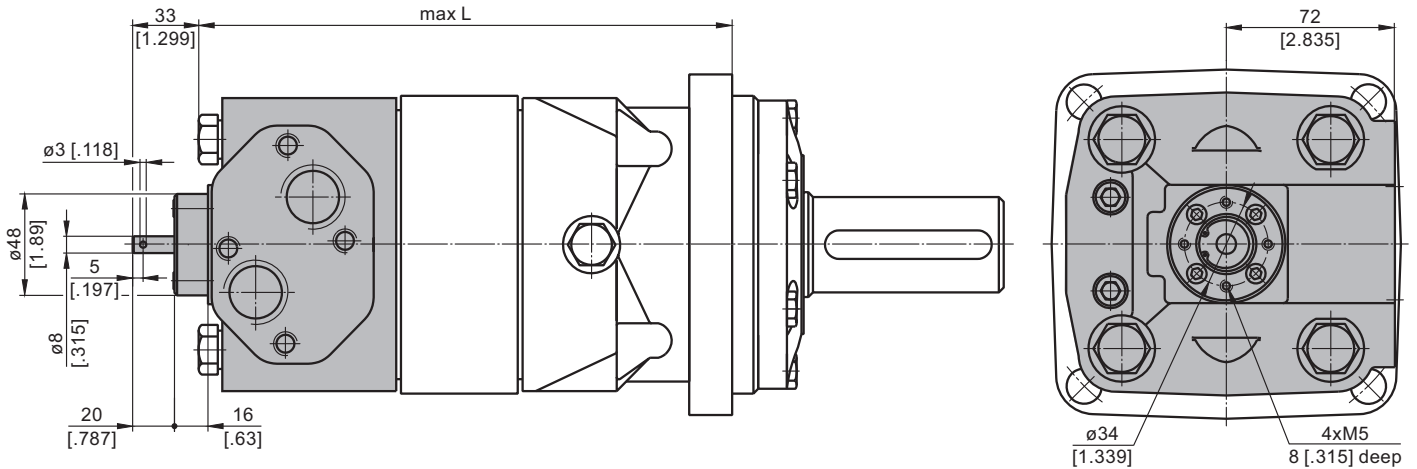

ORDER CODE

	1	2	3	4	5	6	7	8
MT								

Pos.1 - Mounting Flange

omit - Square mount, four holes

S - Short mount

V - Very short mount

W - Wheel mount

Pos.2 - Port type

omit - Side ports

E - Rear ports

Pos.3 - Displacement code

160 - 161,1 cm³/rev [9.83 in³/rev]

200 - 201,4 cm³/rev [12.29 in³/rev]

250 - 251,8 cm³/rev [15.36 in³/rev]

315 - 326,3 cm³/rev [19.90 in³/rev]

400 - 410,9 cm³/rev [25.06 in³/rev]

500 - 523,6 cm³/rev [31.95 in³/rev]

630 - 631,2 cm³/rev [38.59 in³/rev]

725 - 724,3 cm³/rev [44.20 in³/rev]

Pos.4 - Shaft Extensions*

omit - for **S** and **V** mounting flange

C - ø40 straight, Parallel key A12x8x70 DIN6885

CO - ø1½" straight, Parallel key 3/8"x3/8"x2¼" BS46

K - ø45 tapered 1:10, Parallel key B12x8x28 DIN6885

SL - ø34,85 p.t.o. DIN 9611 Form 1

SH - ø1½" splined 17T ANS B92.1-1976

Pos.5 - Shaft Seal Version (see page 34)**

omit - Low pressure seal

U - High pressure seal

Pos.6 - Ports

omit - BSPP (ISO 228)

M - Metric (ISO 262)

Pos.7 - Additional Options (see page 51)

Pos.8 - Design Series

omit - Factory specified

NOTES:

* The permissible output torque for shafts must not be exceeded!

** Shaft seal is available with the "omit" and "W" mounting flange only!

The hydraulic motors are mangano-phosphatized as standard.

HYDRAULIC MOTORS MV



APPLICATION

- » Conveyors
- » Metal working machines
- » Agricultural machines
- » Road building machines
- » Mining machinery
- » Food industries
- » Special vehicles
- » Plastic and rubber machinery etc.

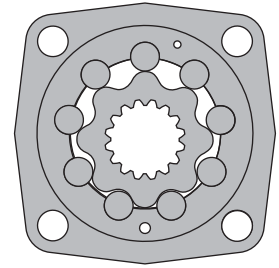
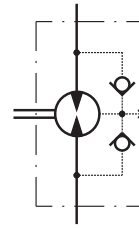

CONTENTS

Specification data	39
Function diagrams	41÷43
Permissible shaft loads	43
Dimensions and mounting	44÷46
Dimensions and mounting - MVS	47
Dimensions and mounting - MVV	48
Internal Spline data	49
Tacho connection.....	49
Shaft extensions	50
Order code	50

OPTIONS

- » Model - Disc valve, roll-gerotor
- » Flange and wheel mount
- » Short motor
- » Tacho connection
- » Speed sensing
- » Side ports
- » Shafts - straight, splined and tapered
- » BSPP ports
- » Other special features

GENERAL

Max. Displacement, cm ³ /rev [in ³ /rev]	801,8 [48.91]
Max. Speed, [RPM]	630
Max. Torque, daNm [lb-in]	cont.: 188 [16650] int.: 211 [18650]
Max. Output, kW [HP]	64 [85,8]
Max. Pressure Drop, bar [PSI]	cont.: 200 [2900] int.: 240 [3480]
Max. Oil Flow, lpm [GPM]	240 [63.4]
Min. Speed, [RPM]	5
Permissible Shaft Loads daN [lbs]	P _a = 1500 [3300]
Pressure fluid	Mineral based- HLP(DIN 51524) or HM(ISO 6743/4)
Temperature range, °C [°F]	-40÷140 [-40÷284]
Optimal Viscosity range, mm ² /s [SUS]	20÷75 [98÷347]
Filtration	ISO code 20/16 (Min. recommended fluid filtration of 25 microns)

Oil flow in drain line

Pressure drop bar [PSI]	Viscosity mm ² /s [SUS]	Oil flow in drain line lpm [GPM]
140 [2030]	20 [98]	3 [.793]
	35 [164]	2 [.528]
210 [3045]	20 [98]	6 [1.585]
	35 [164]	4 [1.057]

Pressure Losses

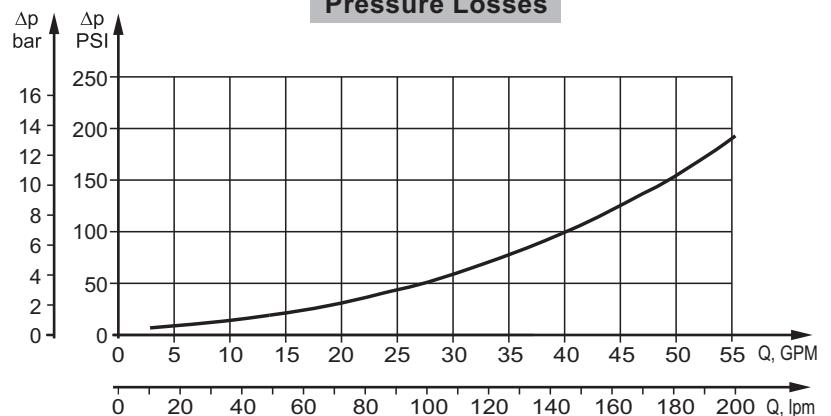

SPECIFICATION DATA

Type		MV 315	MV 400	MV 500	MV 630	MV 800
Displacement, cm³/rev [In³/rev]		314,5 [19.18]	400,9 [24.45]	499,6 [30.48]	629,1 [38.38]	801,8 [48.91]
Max. Speed, [RPM]	Cont.	510	500	400	320	250
	Int.*	630	600	480	380	300
Max. Torque daNm [lb-in]	Cont.	92 [8150]	118 [10450]	146 [12950]	166 [14700]	188 [16650]
	Int.*	111 [9800]	141 [12500]	176 [15550]	194 [17150]	211 [18650]
	Peak**	129 [11400]	164 [14500]	205 [18150]	221 [19550]	247 [21850]
Max. Output kW [HP]	Cont.	42,5 [57]	53,5 [71.7]	53,5 [71.7]	48 [64.4]	42,5 [57]
	Int.*	51 [68.4]	64 [85.8]	64 [85.8]	56 [75]	48 [64.4]
Max. Pressure Drop bar [PSI]	Cont.	200 [2900]	200 [2900]	200 [2900]	180 [2610]	160 [2320]
	Int.*	240 [3480]	240 [3480]	240 [3480]	210 [3050]	180 [2610]
	Peak**	280 [4060]	280 [4060]	280 [4060]	240 [3480]	210 [3050]
Max. Oil Flow lpm [GPM]	Cont.	160 [42.3]	200 [52.8]	200 [52.8]	200 [52.8]	200 [52.8]
	Int.*	200 [52.8]	240 [63.4]	240 [63.4]	240 [63.4]	240 [63.4]
Max. Inlet Pressure bar [PSI]	Cont.	210 [3050]	210 [3050]	210 [3050]	210 [3050]	210 [3050]
	Int.*	250 [3620]	250 [3620]	250 [3620]	250 [3620]	250 [3620]
	Peak**	300 [4350]	300 [4350]	300 [4350]	300 [4350]	300 [4350]
Max. Return Pressure with Drain Line bar [PSI]	Cont.	140 [2040]	140 [2040]	140 [2040]	140 [2040]	140 [2040]
	Int.*	175 [2540]	175 [2540]	175 [2540]	175 [2540]	175 [2540]
	Peak**	210 [3050]	210 [3050]	210 [3050]	210 [3050]	210 [3050]
Max. Starting Pressure with Unloaded Shaft, bar [PSI]		8 [120]	8 [120]	8 [120]	8 [120]	8 [120]
Min. Starting Torque daNm [lb-in]	At max. press. drop Cont.	71 [6300]	91 [8100]	113 [10000]	133 [11800]	151 [13400]
	At max. press. drop Int.*	85 [7500]	109 [9600]	136 [12000]	155 [13700]	170 [15000]
Min. Speed***, [RPM]		10	9	8	6	5
Weight, kg [lb]	MV	31,8 [70.1]	32,6 [71.9]	33,5 [73.8]	34,9 [76.9]	36,5 [80.5]
	MVW	32,4 [71.4]	33,2 [73.2]	34,1 [75.2]	35,5 [78.3]	37,1 [81.8]
	MVS	22,7 [50]	23,5 [51.8]	24,4 [53.8]	25,6 [56.4]	27,7 [61.1]

* Intermittent operation: the permissible values may occur for max. 10% of every minute.

** Peak load: the permissible values may occur for max. 1% of every minute.

*** For speeds lower than given, consult factory or your regional manager.

1. Intermittent speed and intermittent pressure must not occur simultaneously.
2. Recommended filtration is per ISO cleanliness code 20/16. A nominal filtration of 25 micron or better.
3. Recommend using a premium quality, anti-wear type mineral based hydraulic oil HLP(DIN51524) or HM (ISO 6743/4).
If using synthetic fluids consult the factory for alternative seal materials.
4. Recommended minimum oil viscosity 13 mm²/s [70 SUS] at 50°C [122°F].
5. Recommended maximum system operating temperature is 82°C [180°F].
6. To assure optimum motor life fill with fluid prior to loading and run at moderate load and speed for 10-15 minutes.

FUNCTION DIAGRAMS

MV 315

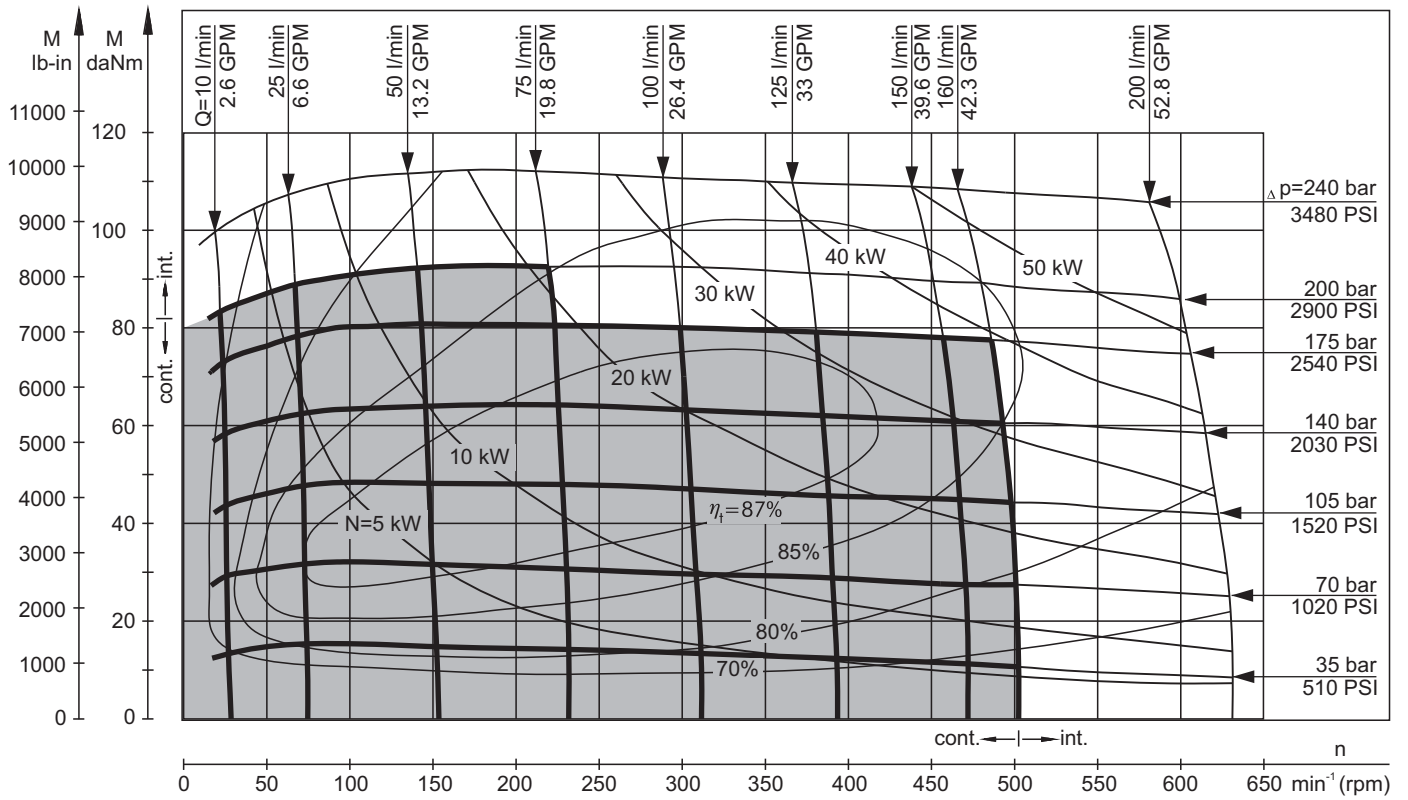

MV 400

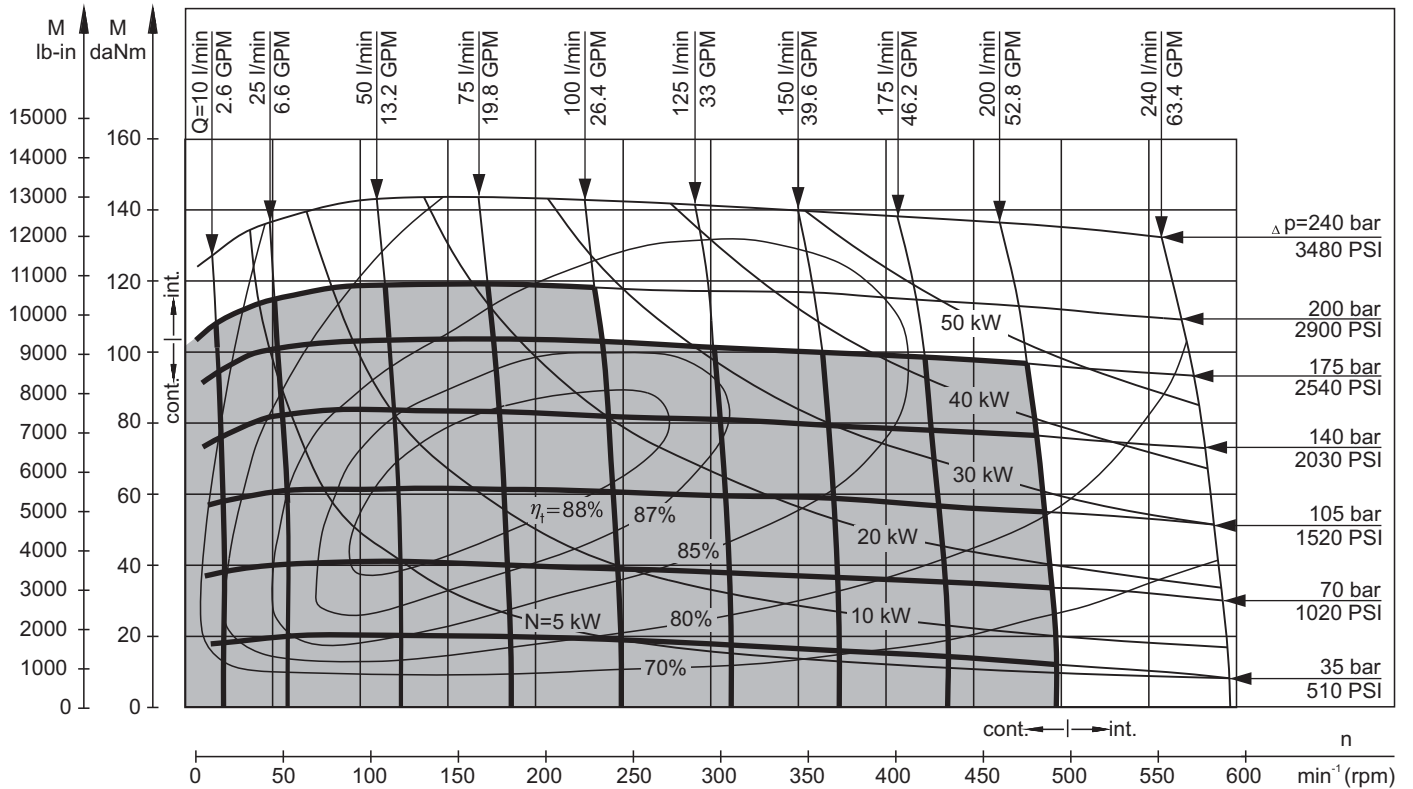

The function diagrams data is for average performance of randomly selected motors at back pressure 5÷10 bar [72.5÷145 PSI] and oil with viscosity of 32 mm²/s [150 SUS] at 50°C [122°F].

FUNCTION DIAGRAMS

MV 500

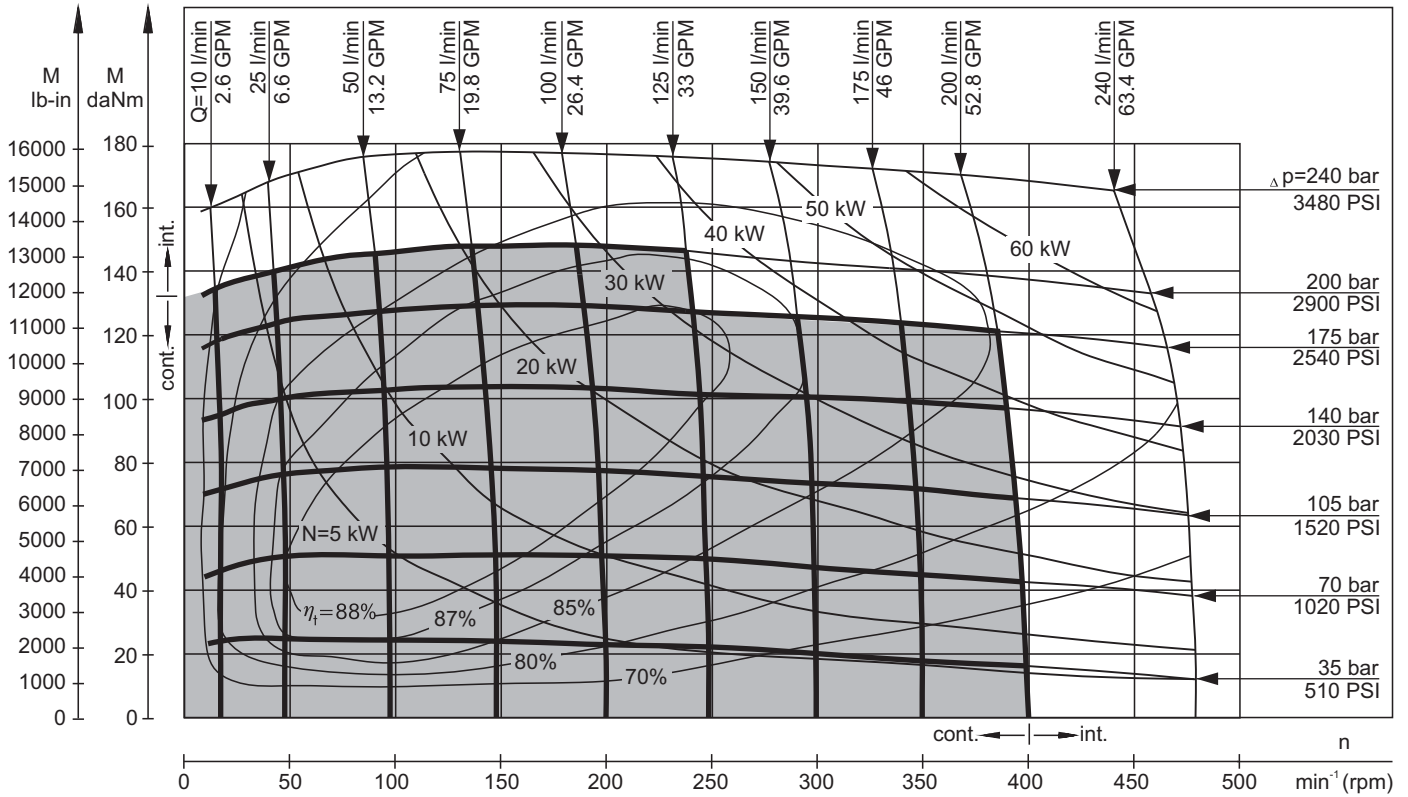

MV 630

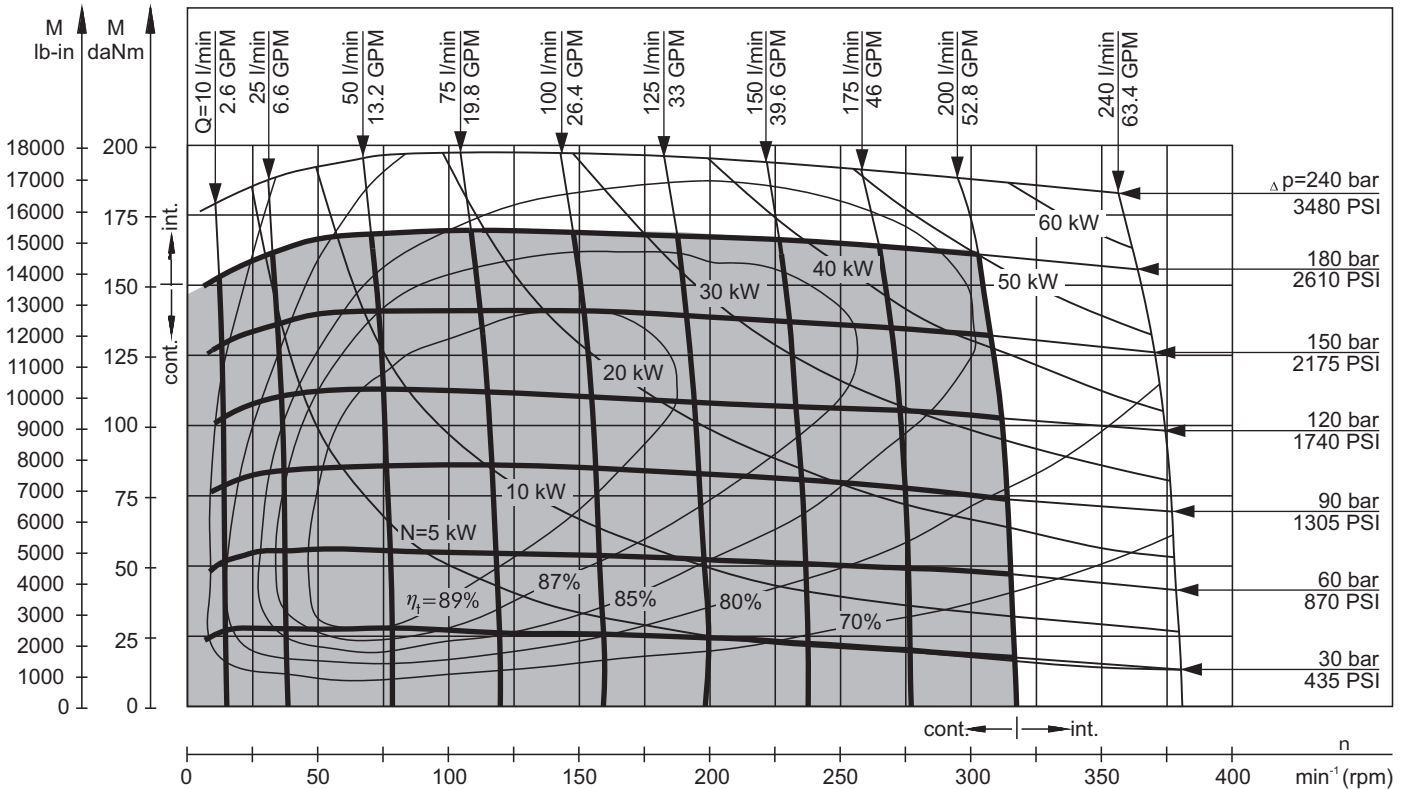

The function diagrams data is for average performance of randomly selected motors at back pressure 5 ÷ 10 bar [72.5 ÷ 145 PSI] and oil with viscosity of 32 mm²/s [150 SUS] at 50°C [122°F].

FUNCTION DIAGRAMS

MV 800

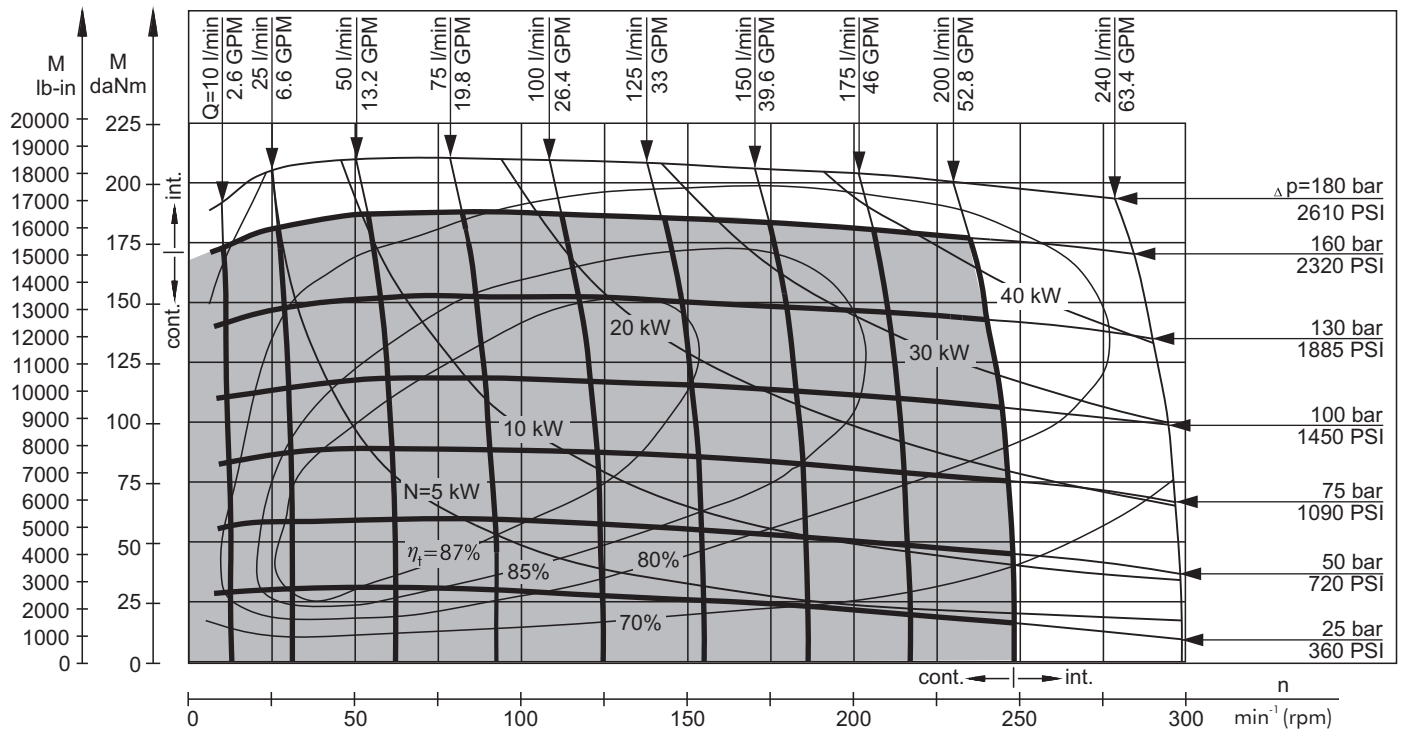

The function diagrams data is for average performance of randomly selected motors at back pressure 5 ± 10 bar [72.5 \pm 145 PSI] and oil with viscosity of 32 mm²/s [150 SUS] at 50°C [122°F].

PERMISSIBLE SHAFT LOADS

The output shaft runs in tapered bearings that permit high axial and radial forces. The permissible radial load on the shaft is shown for an axial load of 0 N as function of the distance from the mounting flange to the point of load application. The curves apply to a B10 bearing life of 2000 hours at 100 RPM.

Curve "1" shows max. radial shaft load. Any shaft load exceeding the values shown by the curve will seriously reduce motor life.

Mounting Flange:

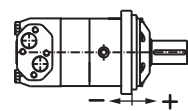
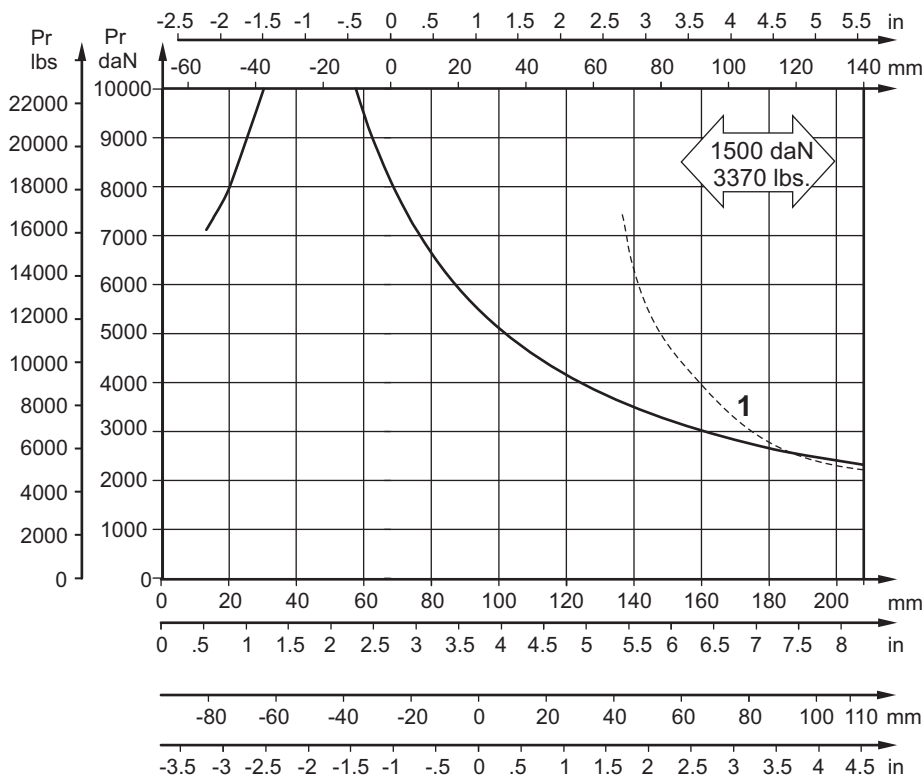

Standard

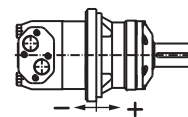

W - Wheel

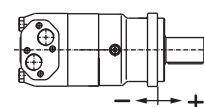

SAE C

DIMENSIONS AND MOUNTING DATA - MV and MVC

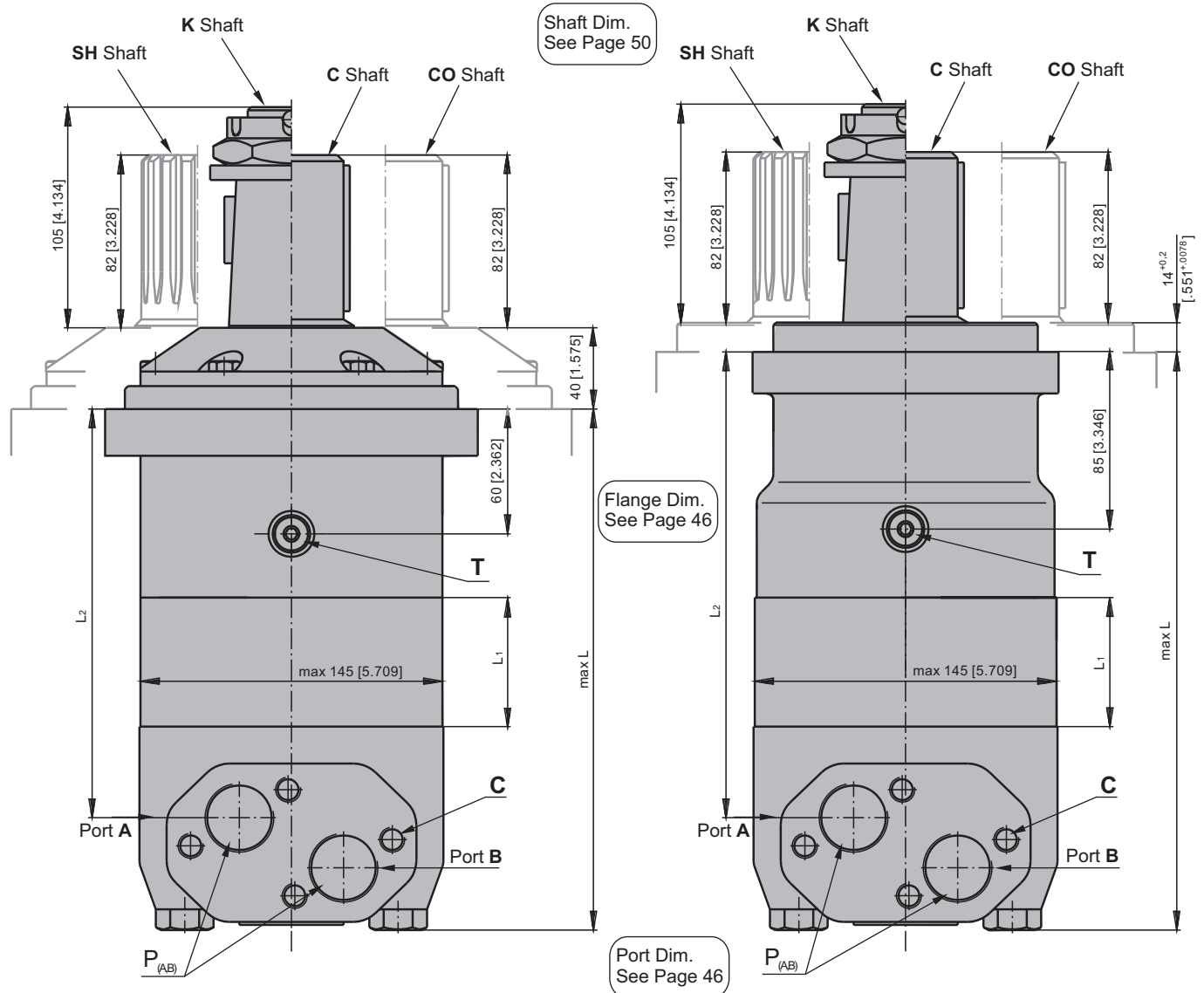

- C** : 4xM12 - 12 mm [.47 in] depth
- P_(A,B)** : 2xG1 - 20 mm [.79 in] depth
- T** : G 1/4 - 12 mm [.47 in] depth

Standard Rotation

Viewed from Shaft End
Port A Pressurized - **CW**
Port B Pressurized - **CCW**

Reverse Rotation

Viewed from Shaft End
Port A Pressurized - **CCW**
Port B Pressurized - **CW**



Type	L, mm [in]	L2, mm [in]	Type	L, mm [in]	L2, mm [in]	*L1, mm [in]
MV 315	214,5 [8.45]	160 [6.30]	MVC 315	239,0 [9.41]	185,5 [7.30]	22,0 [.87]
MV 400	221,5 [8.72]	167 [6.58]	MVC 400	246,0 [9.68]	192,5 [7.58]	29,0 [1.14]
MV 500	229,5 [9.04]	175 [6.89]	MVC 500	254,0 [10.0]	200,5 [7.89]	37,0 [1.46]
MV 630	240,0 [9.45]	186 [7.32]	MVC 630	264,5 [10.41]	211,0 [8.31]	47,5 [1.87]
MV 800	254,0 [10.0]	200 [7.87]	MVC 800	278,5 [10.96]	225,0 [8.86]	61,5 [2.42]

* The width of the roll-gerotor is 4 mm [.157 in.] greater than L1.

DIMENSIONS AND MOUNTING DATA - MVW

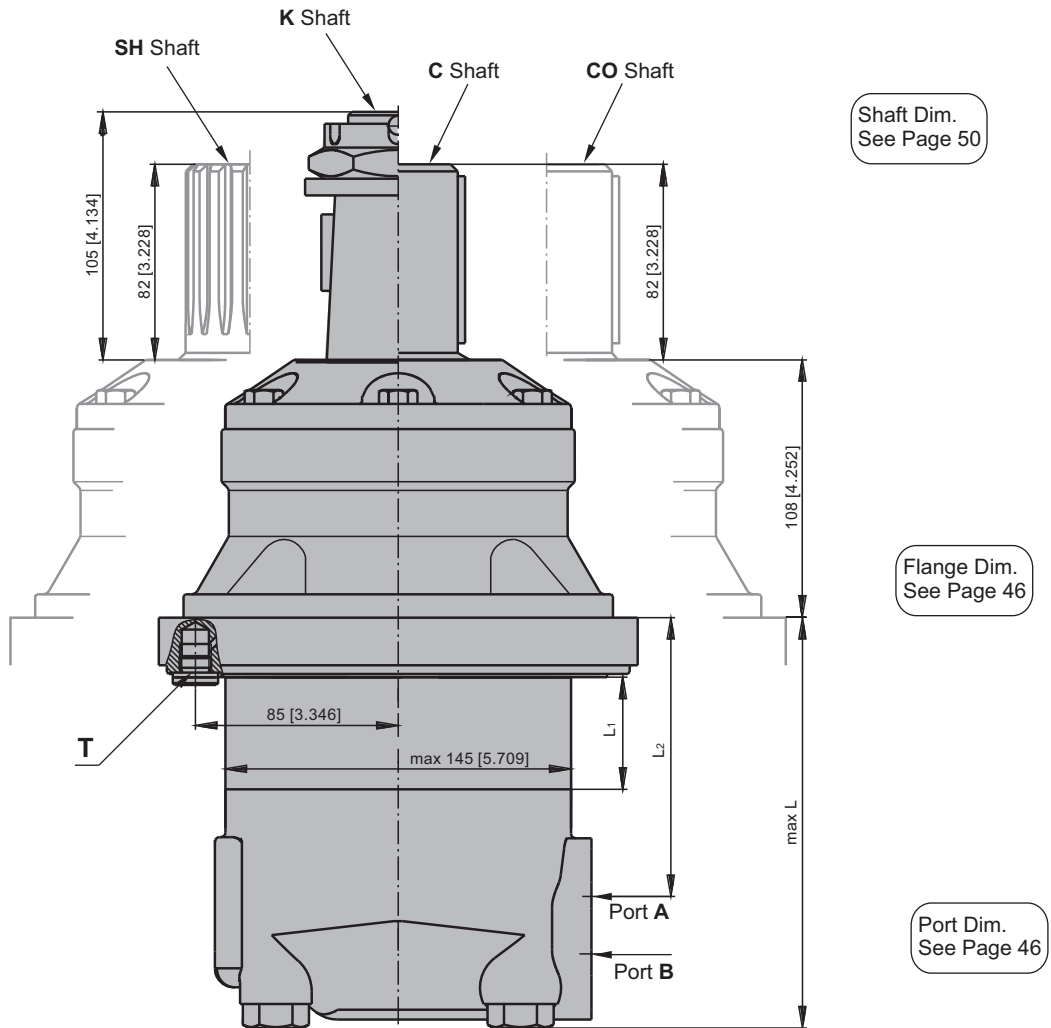

- C** : 4xM12 - 12 mm [.47 in] depth
- P_(A,B)** : 2xG1 - 20 mm [.79 in] depth
- T** : G 1/4 - 12 mm [.47 in] depth

Standard Rotation
Viewed from Shaft End
Port **A** Pressurized - **CW**
Port **B** Pressurized - **CCW**

Reverse Rotation
Viewed from Shaft End
Port **A** Pressurized - **CCW**
Port **B** Pressurized - **CW**



Type	L, mm [in]	L2, mm [in]	*L1, mm [in]
MVW 315	146 [5.75]	92 [3.62]	22,0 [.87]
MVW 400	153 [6.02]	99 [3.90]	29,0 [1.14]
MVW 500	161 [6.34]	107 [4.21]	37,0 [1.46]
MVW 630	172 [6.77]	118 [4.65]	47,5 [1.87]
MVW 800	185 [7.28]	132 [5.20]	61,5 [2.42]

* The width of the roll-gerotor is 4 mm [.157 in.] greater than L1.

MOUNTING

Square Mount (4 Holes)

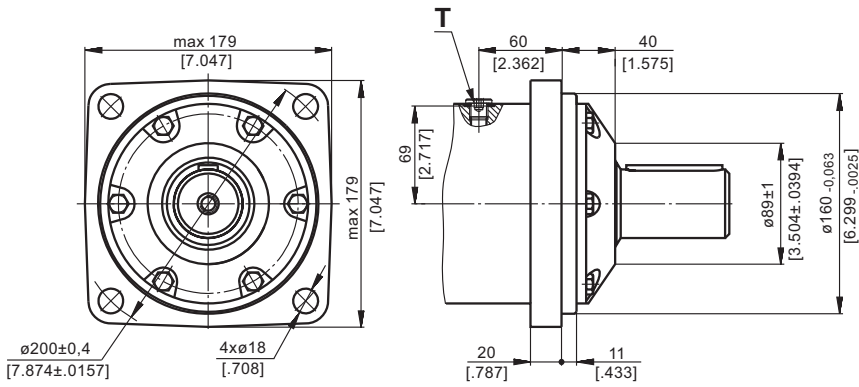

C SAE C Mount

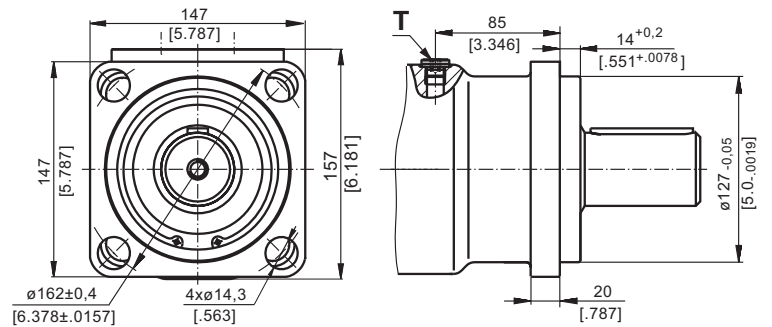

W Wheel Mount

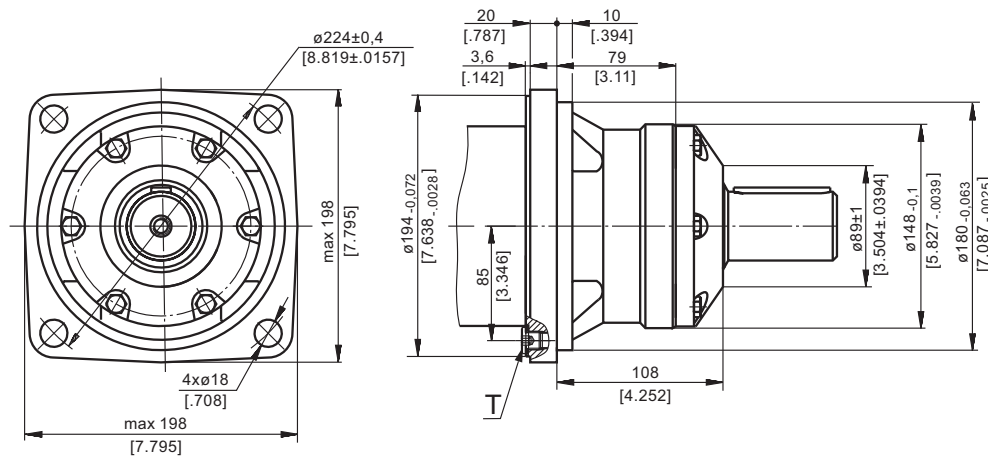

PORTS

Side Ports

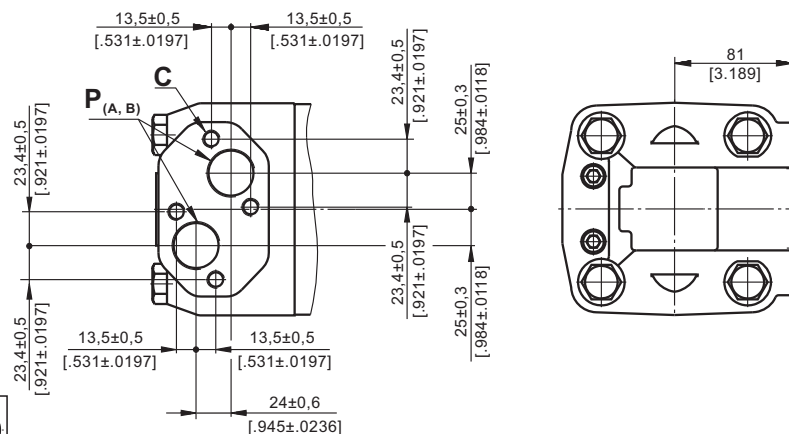

- C** : 4xM12 - 12 mm [0.47 in] depth
- P_(A,B)** : 2xG1 - 20 mm [0.79 in] depth
- T** : G 1/4 - 12 mm [0.47 in] depth

Standard Rotation
Viewed from Shaft End
Port A Pressurized - **CW**
Port B Pressurized - **CCW**

Reverse Rotation
Viewed from Shaft End
Port A Pressurized - **CCW**
Port B Pressurized - **CW**



DIMENSIONS AND MOUNTING

S Short Mount

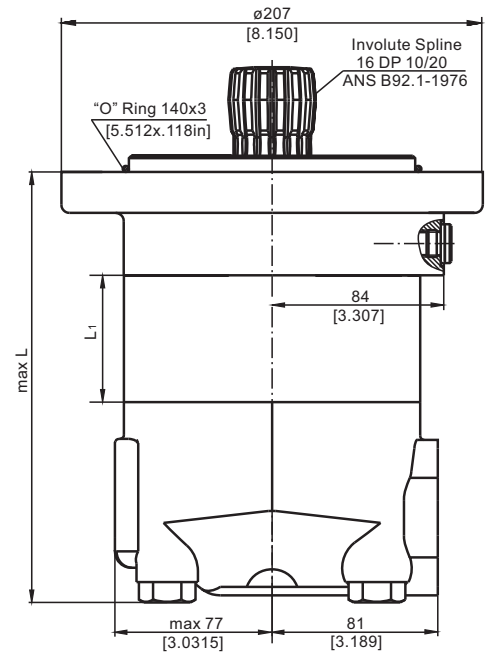
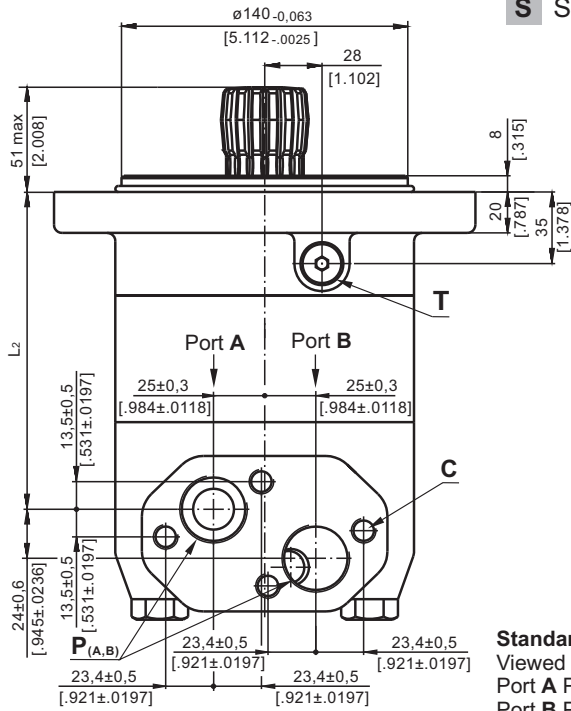

- C** : 4xM12 - 12 mm [0.47 in] depth
- P_(A,B)** : 2xG1 - 20 mm [0.79 in] depth
- T** : G 1/4 - 12 mm [0.47 in] depth

- Standard Rotation**
Viewed from Shaft End
Port A Pressurized - CW
Port B Pressurized - CCW
- Reverse Rotation**
Viewed from Shaft End
Port A Pressurized - CCW
Port B Pressurized - CW

Type	L, mm [in]	L ₂ , mm [in]	*L ₁ , mm [in]
MVS 315	171[6.73]	117[4.61]	22,0 [0.87]
MVS 400	179[7.05]	124[4.88]	29,0 [1.14]
MVS 500	186[7.32]	132[5.20]	37,0 [1.46]
MVS 630	197[7.76]	143[5.63]	47,5 [1.87]
MVS 800	211[8.31]	157[6.18]	61,5 [2.42]

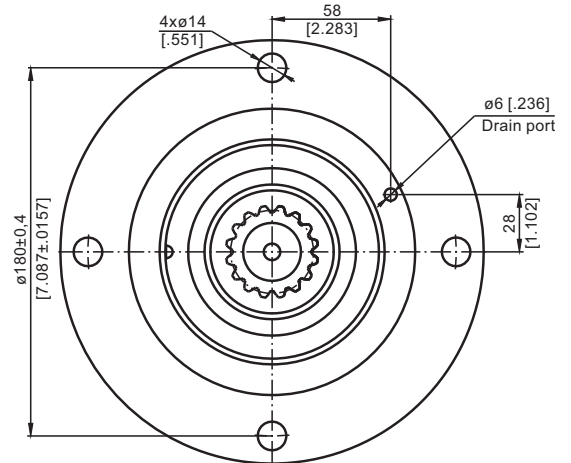

* The width of the roll-gerotor is 4 mm [0.157 in] greater than L₁.

DIMENSIONS OF THE ATTACHED COMPONENT

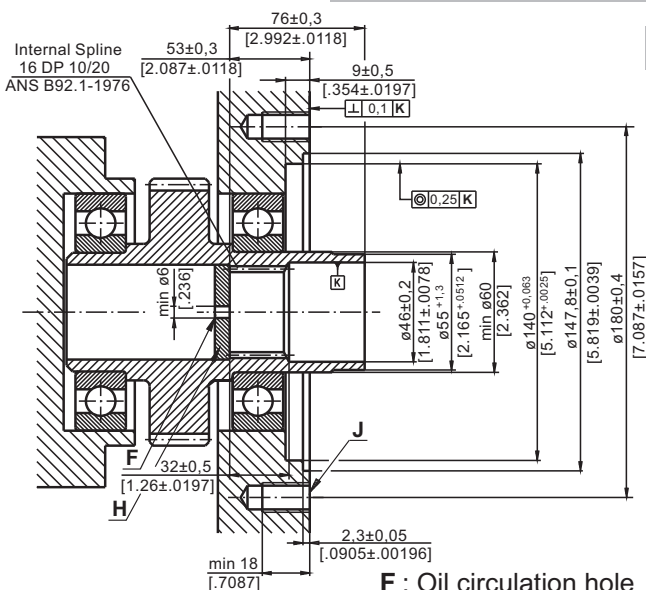

MVS

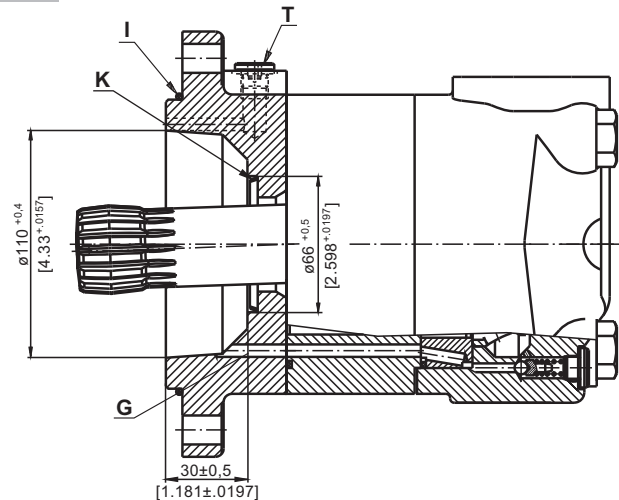

- F** : Oil circulation hole
- G** : Internal drain channel
- H** : Hardened stop plate
- I** : O-Ring 140x3mm [5.512x.118in]

- J** : 4xM12-18 mm [0.709 in] depth, 90°
- K** : Conical seal ring
- T** : Drain connection G1/4 - 12 mm [0.47 in] depth



DIMENSIONS AND MOUNTING

V Very Short Mount

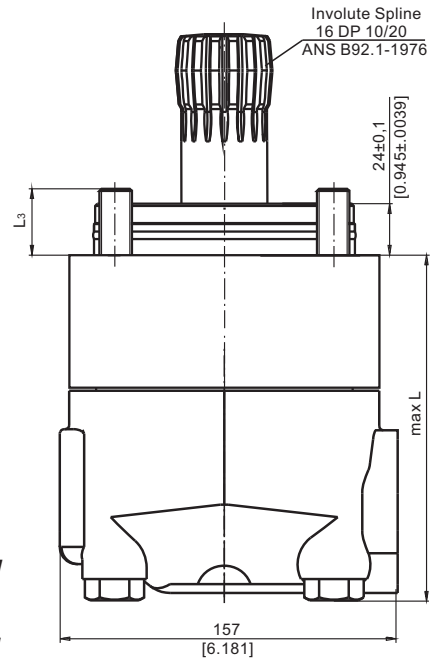
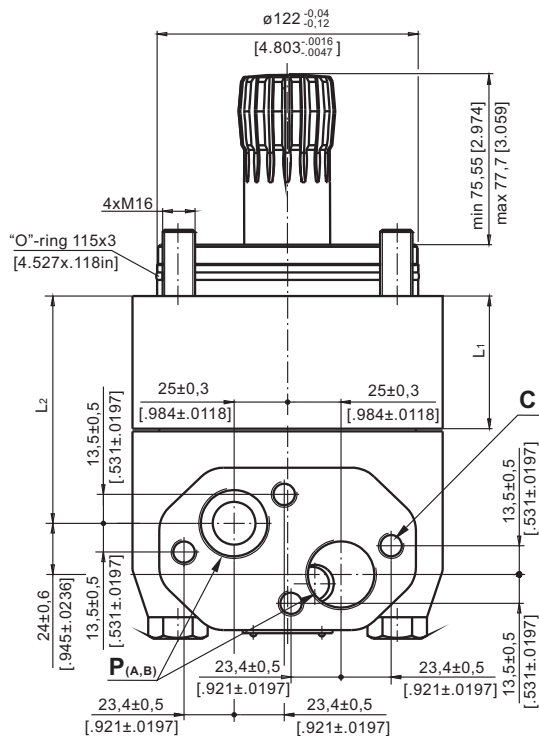

Standard Rotation
Viewed from Shaft End
Port A Pressurized - CW
Port B Pressurized - CCW

Reverse Rotation
Viewed from Shaft End
Port A Pressurized - CCW
Port B Pressurized - CW

C : 4xM12 - 12 mm [.47 in] depth
P_(A,B) : 2xG1 - 20 mm [.79 in] depth

Type	L, mm[in.]	L2, mm [in.]	L3, mm [in.]	*L1, mm [in.]
MVV 315	121,5[4.78]	68[2.68]	29,5[1.16]	22,0 [.87]
MVV 400	128,5[5.06]	75[2.95]	32,5[1.28]	29,0 [1.14]
MVV 500	136,5[5.37]	83[3.27]	34,5[1.36]	37,0 [1.46]
MVV 630	147,0[5.79]	93[3.66]	34,0[1.34]	47,5 [1.87]
MVV 800	161,0[6.34]	107,5[4.23]	30,0[1.18]	61,5 [2.42]

* The width of the roll-gerotor is 4 mm [.157 in] greater than L1.

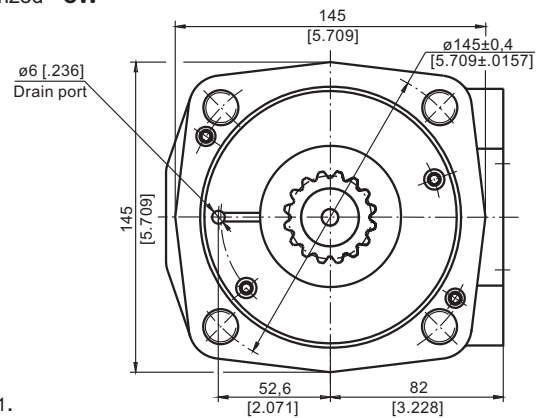

DIMENSIONS OF THE ATTACHED COMPONENT

MVV

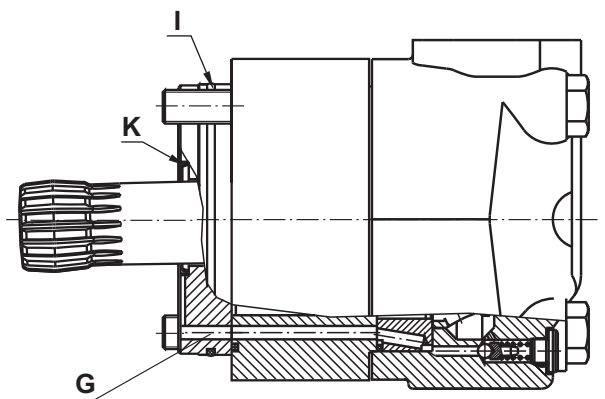
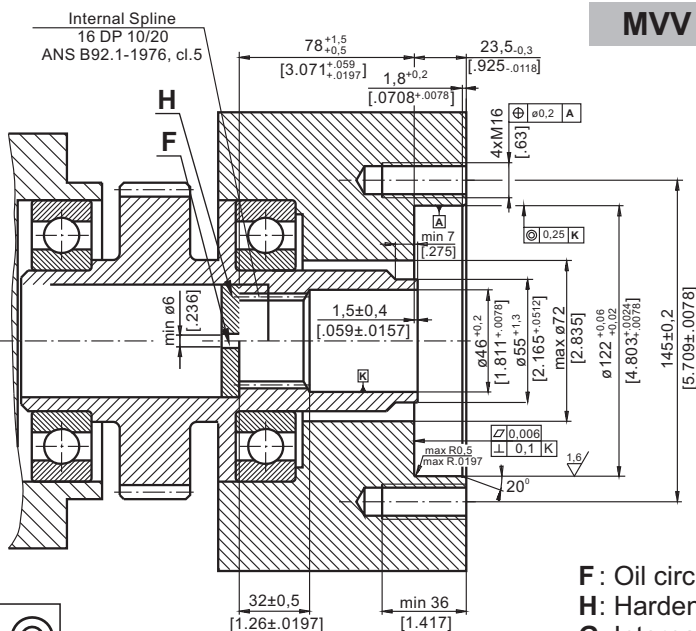

F : Oil circulation hole
H : Hardened stop plate
G : Internal drain channel

I : O-Ring 115x3 mm [4.527x.118 in]
K : Conical seal ring



DRAIN CONNECTION

A drain line has to be used when pressure in the return line can exceed the permissible pressure. It can be connected:

- For MVS to the drain port of the motor;
- For MVV to the drain connection of the attached component. The maximum pressure in the drain line is limited by the attached component and its shaft seal.

The drain line must be possible for oil to flow freely between motor and attached component and must be led to the tank. The maximum pressure in the drain line is limited by the attached component and its seal.

INTERNAL SPLINE DATA FOR THE ATTACHED COMPONENT

Standard ANS B92.1-1976, class 5
[$m=2.54$; corrected $x.m=+1,0$]

Flat Root Side Fit		mm	inch
Number of Teeth	z	16	16
Diametral Pitch	DP	10/20	10/20
Pressure Angle		30°	30°
Pitch Dia.	D	40,640	1.6
Major Dia.	D _{ri}	45,2 ^{+0,4}	1.796±1.780
Minor Dia.	D _i	38,5 ^{+0,039}	1.5175±1.516
Space Width [Circular]	Lo	5,18±0,037	.2055±.2025
Fillet Radius	R	0,4	.015
Max. Measurement between Pins	L	32,47 ^{+0,15}	1.284±1.278
Pin Dia.	d	5,6±0,001	.22051±.22043

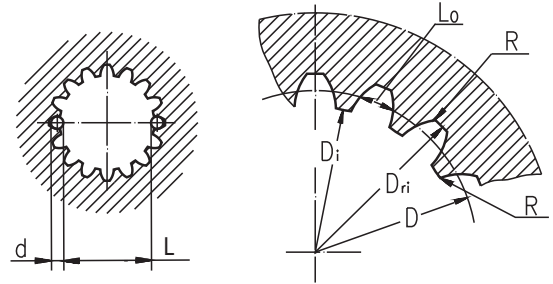

Hardening Specification:
 HV=750±50 on the surface.
 HV=560 at 0,7±0,2 mm [.035±.019in] case depth
 Material: 20 MoCr4 EN 10084 or better.

MOTOR WITH TACHO CONNECTION

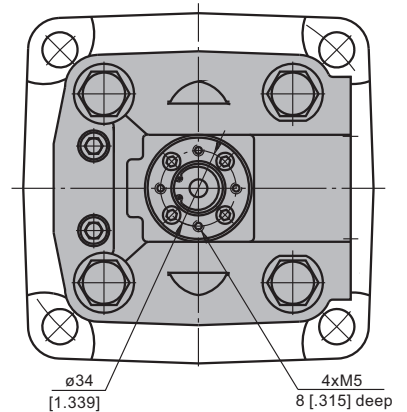
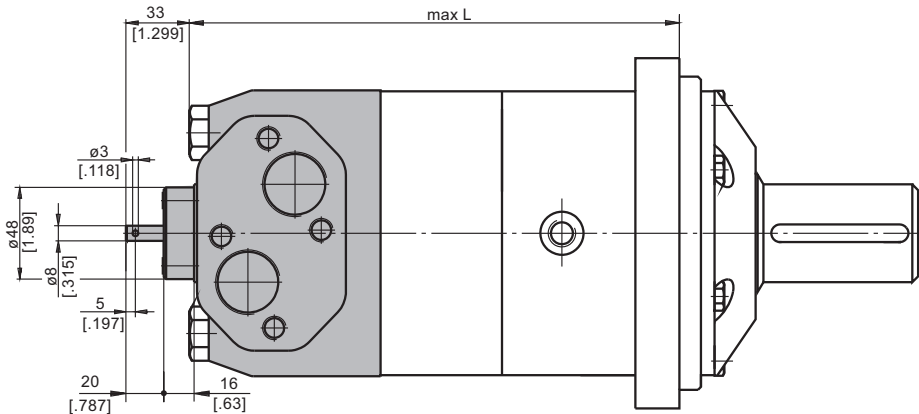

MAX. PERMISSIBLE SHAFT SEAL PRESSURE for MV motors

Max. return pressure without drain line or
max. pressure in the drain line

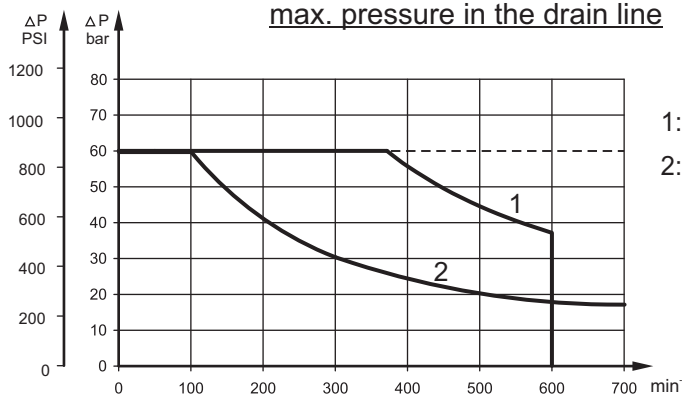

- 1: Drawing for High Pressure Seal ("U" Seal)
- 2: Drawing for Standard Shaft Seal

— - continuous operations
 - - - - intermittent operations



SHAFT EXTENSIONS

C - $\varnothing 50$ straight, Parallel key A14x9x70 DIN 6885
Max. Torque 271,2 daNm [24000 lb-in]

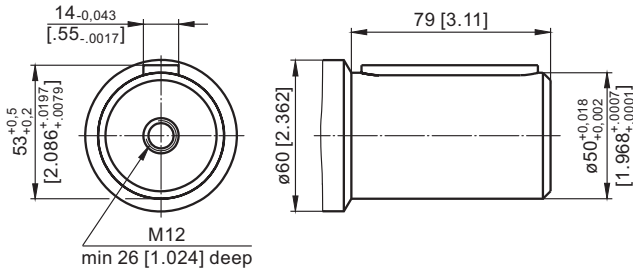

CO - $\varnothing 2\frac{1}{4}$ " [57,15] straight, Parallel key $\frac{1}{2}$ "x $\frac{1}{2}$ "x 2 $\frac{1}{4}$ " BS46
Max. Torque 271,2 daNm [24000 lb-in]

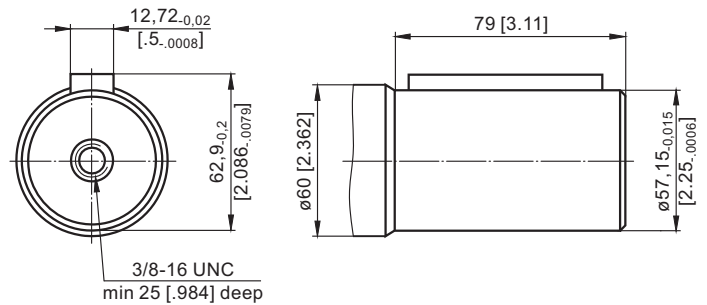

SH - $\varnothing 2\frac{1}{8}$ " splined, 16 DP 8/16 ANS B92.1-1976
Max. Torque 271,2 daNm [24000 lb-in]

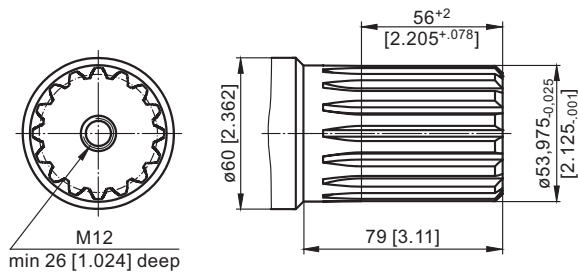

K - tapered 1:10, Parallel key B16x10x32 DIN 6885
Max. Torque 271,2 daNm [24000 lb-in]

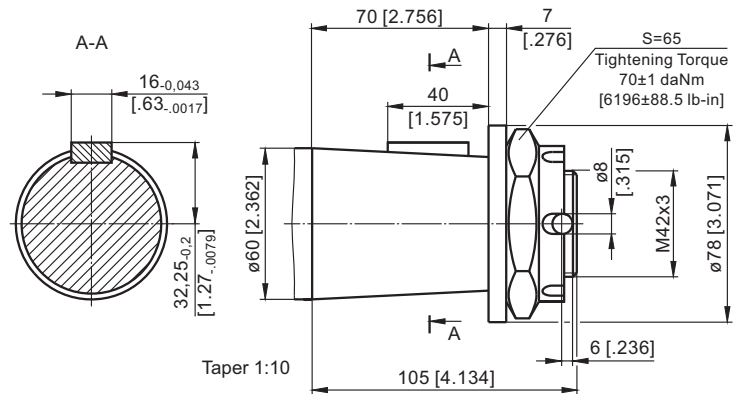

ORDER CODE

	1	2	3	4	5	6
M V						

Pos.1 - Mounting Flange

- omit - Square mount, four holes
- C** - SAE C mount
- W** - Wheel mount
- S** - Short mount
- V** - Very short mount

Pos.2 - Displacement code

- 315** - 314,5 cm³/rev [19.18 in³/rev]
- 400** - 400,9 cm³/rev [24.45 in³/rev]
- 500** - 499,6 cm³/rev [30.48 in³/rev]
- 630** - 629,1 cm³/rev [38.38 in³/rev]
- 800** - 801,8 cm³/rev [48.91 in³/rev]

Pos.3 - Shaft extensions*

- omit - for **S** and **V** mounting flange
- C** - $\varnothing 50$ straight, Parallel key A14x9x70 DIN6885
- CO** - $\varnothing 2\frac{1}{4}$ " straight, Parallel key $\frac{1}{2}$ "x $\frac{1}{2}$ "x 2 $\frac{1}{4}$ " BS46
- SH** - $\varnothing 2\frac{1}{8}$ " splined, ANS B92.1-1976
- K** - $\varnothing 60$ tapered 1:10, Parallel key B16x10x32 DIN6885

Pos.4 - Shaft Seal Version (see page 49)**

- omit - Low pressure shaft seal
- U** - High pressure shaft seal

Pos.5 - Additional Options (see page 51)

Pos.6 - Design Series

- omit - Factory specified

NOTES:

- * The permissible output torque for shafts must not be exceeded!
- ** Shaft seal is available with the "omit" and "W" mounting flange only!

The hydraulic motors are mangan- phosphatized as standard.

MOTOR ADDITIONAL OPTIONS

Additional Options Description	Order Code	Motor type		
		MS	MT	MV
Speed Sensor*	RS	○	○	○
Tacho Connection**	T	○	○	○
Reinforced motor	HD	-	○	○
Reinforced motor (with check valves)	1HD	-	○	○
Low Leakage	LL	○	○	○
Low Speed Valving	LSV	○	○	○
Reverse Rotation	R	○	○	○
Paint***	P	○	○	○
Corrosion Protected Paint***	PC	○	○	○
Special Paint****	PS	○	○	○
	PCS			

○	Optional
-	Not applicable

- * For sensor ordering see pages 52+53.
- ** For side ports only!
- *** Colour at customer's request.
- **** Non painted feeding surfaces, colour at customer's request.

⚠ For more information about HD option please contact with "M+S Hydraulic".

MOTORS WITH SPEED SENSOR

MS...RS

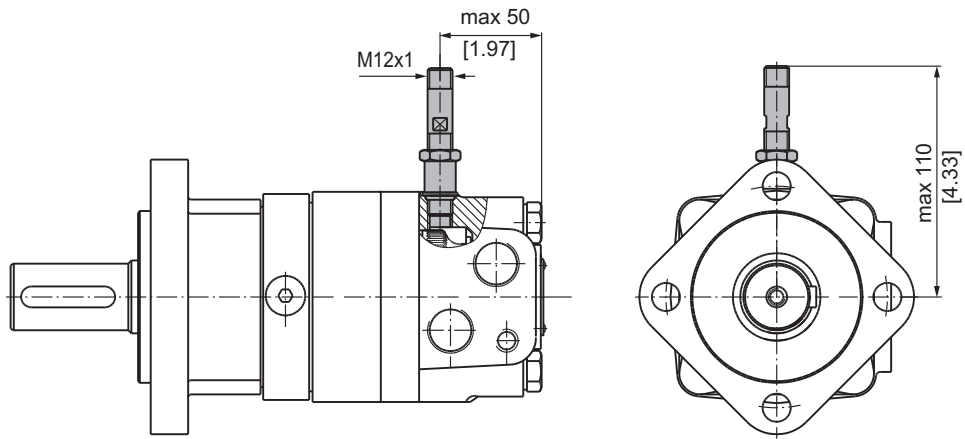

MT...RS

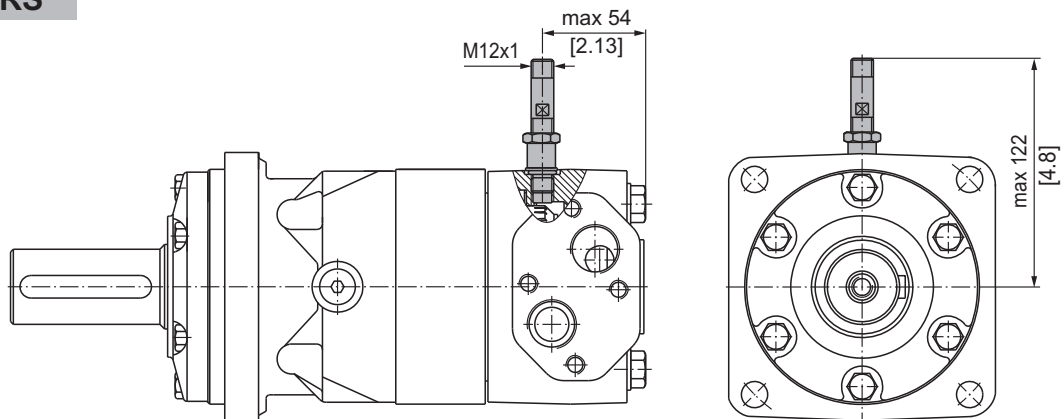

MV...RS

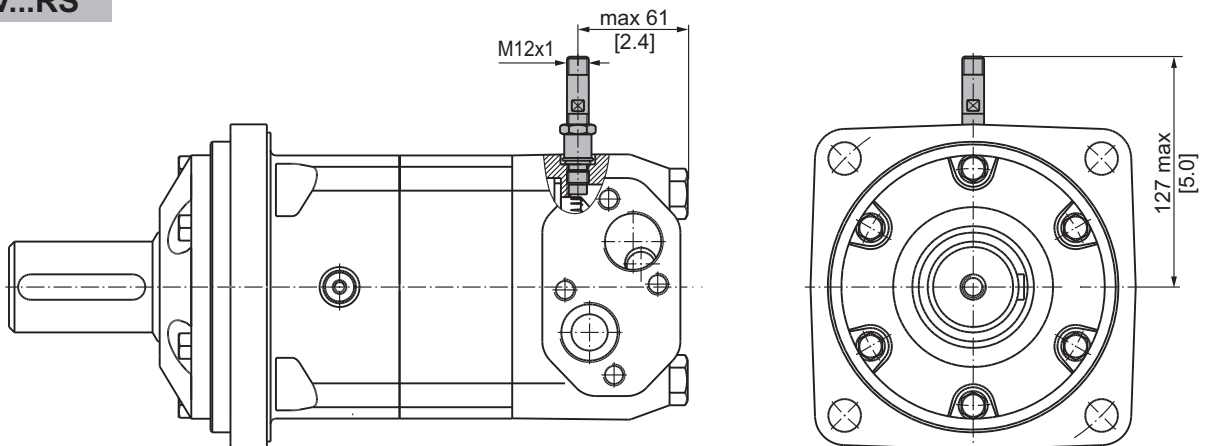

TECHNICAL DATA OF THE SPEED SENSOR

Technical data

Frequency range	0...15 000 Hz
Output	Universal PUSH PULL
Power supply	10-30 VDC
Current input	<20 mA (@24 VDC)
Maximum output current	500 mA
Ambient Temperature	-40...+125°C [-40...+257°F]
Protection	IP 67
Plug connector	M12-Series
Mounting principle	ISO 6149

Output signal

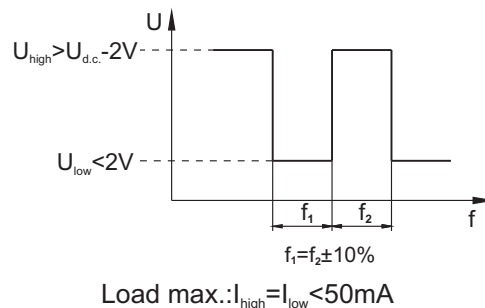

Motor type	MS	MT	MV
Pulses per revolution	54	84	102

Wiring diagrams

PNP

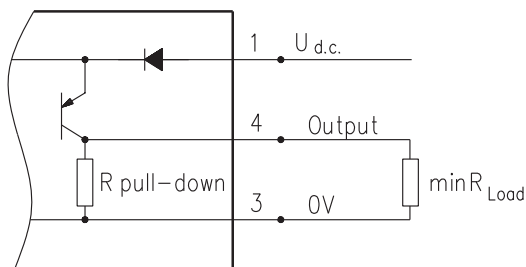

NPN

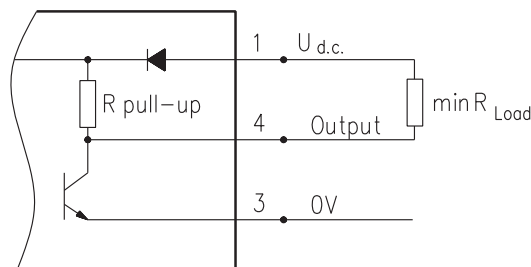

$$R_{Load} [k\Omega] = U_{d.c.} [V] / I_{max} [mA]$$

Stick type

Order Code for Speed Sensor

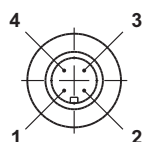

Terminal No.	Connection	Cable Output
1	U _{d.c.}	Brown
2	No connection	White
3	0V	Blue
4	Output signal	Black

Sensor Code	Electric connection
RS	Connector BINDER 713 series
RSL2,5	Cable output 3x0,25; 2,5 m [98 in] long
RSL3,5	Cable output 3x0,25; 3,5 m [138 in] long
RSL5	Cable output 3x0,25; 5 m [196 in] long
RSL10	Cable output 3x0,25; 10 m [394 in] long

NOTE: * - The speed sensor is not fitted at the factory, but is supplied in a plastic bag with the motor. For installation see enclosed instructions.

APPLICATION CALCULATION

VEHICLE DRIVE CALCULATIONS

1. Motor speed: n, RPM

$$n = \frac{2,65 \times v_{km} \times i}{R_m} \quad n = \frac{168 \times v_{mi} \times i}{R_{in}}$$

v_{km} - vehicle speed, km/h;

v_{mi} - vehicle speed, mil/h;

R_m - wheel rolling radius, m;

R_{in} - wheel rolling radius, in;

i - gear ratio between motor and wheels.

If no gearbox, use $i=1$.

2. Rolling resistance: RR, daN [lbs]

The resistance force resulted in wheels contact with different surfaces:

$$RR = G \times \rho$$

G - total weight loaded on vehicle, daN [lbs];

ρ - rolling resistance coefficient (Table 1).

Table 1

Rolling resistance coefficient In case of rubber tire rolling on different surfaces	
Surface	ρ
Concrete- faultless	0.010
Concrete- good	0.015
Concrete- bad	0.020
Asphalt- faultless	0.012
Asphalt- good	0.017
Asphalt- bad	0.022
Macadam- faultless	0.015
Macadam- good	0.022
Macadam- bad	0.037
Snow- 5 cm	0.025
Snow- 10 cm	0.037
Polluted covering- smooth	0.025
Polluted covering- sandy	0.040
Mud	0.037÷0.150
Sand- Gravel	0.060÷0.150
Sand- loose	0.160÷0.300

3. Grade resistance: GR, daN [lbs]

$$GR = G \times (\sin \alpha + \rho \times \cos \alpha)$$

α - gradient negotiation angle (Table 2)

Table 2

Grade %	α Degrees	Grade %	α Degrees
1%	0° 35'	12%	6° 5'
2%	1° 9'	15%	8° 31'
5%	2° 51'	20%	11° 19'
6%	3° 26'	25%	14° 3'
8%	4° 35'	32%	18°
10%	5° 43'	60%	31°

4. Acceleration force: FA, daN [lbs]

Force FA necessary for acceleration from 0 to maximum speed v and time t can be calculated with a formula:

$$FA = \frac{v_{km} \times G}{36 \times t}, [\text{daN}] \quad FA = \frac{v_{mi} \times G}{22 \times t}, [\text{lbs}];$$

FA - acceleration force, daN [lbs];

t - time, [s].

5. Tractive effort: DP, daN [lbs]

Tractive effort DP is the additional force of trailer. This value will be established as follows:

-acc.to constructor's assessment;

-as calculating forces in items 2, 3 and 4 of trailer; the calculated sum corresponds to the tractive effort requested.

6. Total tractive effort: TE, daN [lbs]

Total tractive effort TE is total effort necessary for vehicle motion; that the sum of forces calculated in items from 2 to 5 and increased with 10 % because of air resistance.

$$TE = 1,1 \times (RR + GR + FA + DP)$$

RR - force acquired to overcome the rolling resistance;

GR - force acquired to slope upwards;

FA - force acquired to accelerate (acceleration force);

DP - additional tractive effort (trailer).

7. Motor Torque moment: M, daNm [lb-in]

Necessary torque moment for every hydraulic motor:

$$M = \frac{TE \times R_{in} [R_m]}{N \times i \times \eta_M}$$

N - motor numbers;

η_M - mechanical gear efficiency (if it is available).

8. Cohesion between tire and road covering: M_w, daNm [lb-in]

$$M_w = \frac{G_w \times f \times R_{in} [R_m]}{i \times \eta_M}$$

To avoid wheel slipping, the following condition should be observed $M_w > M$

f - frictional factor;

G_w - total weight over the wheels, daN [lbs].

Table 3

Surface	Frictional factor f
Steel on steel	0.15 ÷ 0.20
Rubber tire on polluted surface	0.5 ÷ 0.7
Rubber tire on asphalt	0.8 ÷ 1.0
Rubber tire on concrete	0.8 ÷ 1.0
Rubber tire on grass	0.4

9.Radial motor loading: P_{rad} , daN [lbs]

When motor is used for vehicle motion with wheels mounted directly on motor shaft, the total radial loading of motor shaft P_{rad} is a sum of motion force and weight force acting on one wheel.

- G_w - Weight held by wheel;
- P_{rad} - Total radial loading of motor shaft;
- M/R - Motion force.

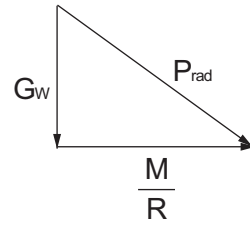

$$P_{rad} = \sqrt{G_w^2 + \left(\frac{M}{R}\right)^2}$$

In accordance with calculated loadings the suitable motor from the catalogue is selected.

DRAINAGE SPACE AND DRAINAGE PRESSURE

Advantages in oil drainage from drain space: Cleaning; Cooling and Seal lifetime prolonging.

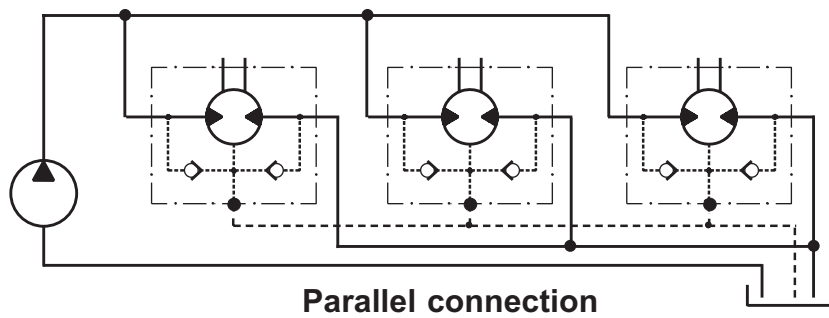
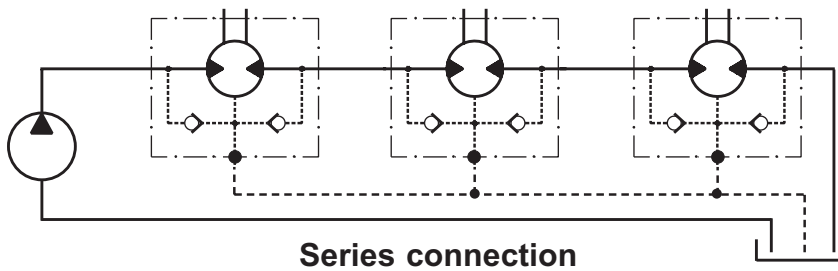

WARRANTY

M+S Hydraulic warrants, that its products, supplied directly to original equipment manufacturer, authorized distributor or other customer, will be free of defects in material or workmanship at the time of shipment from M+S Hydraulic and will conform to the products technical documentation (drawings and specifications) under sale agreement with Buyer.

This warranty will apply only to defects appearing within applicable Warranty period, mentioned below. If Buyer notifies M+S Hydraulic within the Warranty period about any such defects, M+S, at its sole option will replace or repair the defective products or their parts found by M+S Hydraulic to be defective in material or workmanship.

THE FOREGOING LIMITED WARRANTY IS AVAILABLE ONLY IF "M+S HYDRAULIC" IS PROMPTLY NOTIFIED IN WRITTEN OF THE ALLEGED DEFECT AND DOES NOT COVER FAILURE TO FUNCTION CAUSED BY DAMAGE TO THE PRODUCT, IMPROPER INSTALLATION, UNREASONABLE USE OR ABUSE OF THE PRODUCT, FAILURE TO PROVIDE OR USE OF IMPROPER MAINTENANCE OR USUAL, DEGRADATION OF THE PRODUCT DUE TO PHYSICAL ENVIRONMENTS OF AN USUAL NATURE. THE FOREGOING REMEDIES ARE THE SOLE AND EXCLUSIVE REMEDIES AVAILABLE TO CUSTOMER. To facilitate the inspection, M+S Hydraulic may require return of the product/part, which Buyer claims to be defective.

M+S Hydraulic shall not be liable for labor costs or any other expenses incurred during the disassembling or reinstalling of the product/part.

In case the claimed products are returned to M+S Hydraulic in bad condition: dirty, disassembled, with damaged or missing parts during transportation, the warranty will be considered as not applicable and the products will not be liable to repair.

Warranty periods

New products: The Warranty period is limited to 24 consecutive months (2 years) from the date of production of the product.

Repaired products: If the product is repaired in M+S Hydraulic during its warranty period, the warranty period of the repaired item shall continue for the balance of original Warranty period or for a period equal to 50% of the original new product Warranty period, whichever is later.

Spare parts: The Warranty period for Spare parts is 12 consecutive months (1 year) from the dispatch date of such parts from M+S Hydraulic.

LIMITATION OF LIABILITY M+S Hydraulic's liability for claim of any kind, for loss or damage arising out of, connected with or resulting from an order, or from the performance or branch thereof, or from the design, manufacture, sale delivery, operation or use of any of its products shall be limited to, at M+S 's sole option, replacement, repair of any defective product or the issuance of a credit to Customer against any future purchases. Cash refunds will not be made under any circumstances and Customer will not be entitled to recover any damages of any kind against M+S Hydraulic, including but not limited to incidental or consequential damages, whether direct or indirect, known or unknown, foreseen or unforeseen.



M+S HYDRAULIC

68, Kozloduy St., 6100 Kazanlak, Bulgaria

Tel.: ++359 431 65167

++359 431 64271

Fax: +359 431 64114

E-Mail: msh@ms-hydraulic.com

URL: <http://www.ms-hydraulic.com>