

**PRESA DI FORZA A
COMANDO PNEUMATICO
PNEUMATIC CLUTCH
POWER TAKE-OFF**

CODICE PTO
PTO CODE

010-029-00130

CAMBIO
GEARBOX

ZF



DIAGRAMMA DI UTILIZZO
WORKING CONDITION

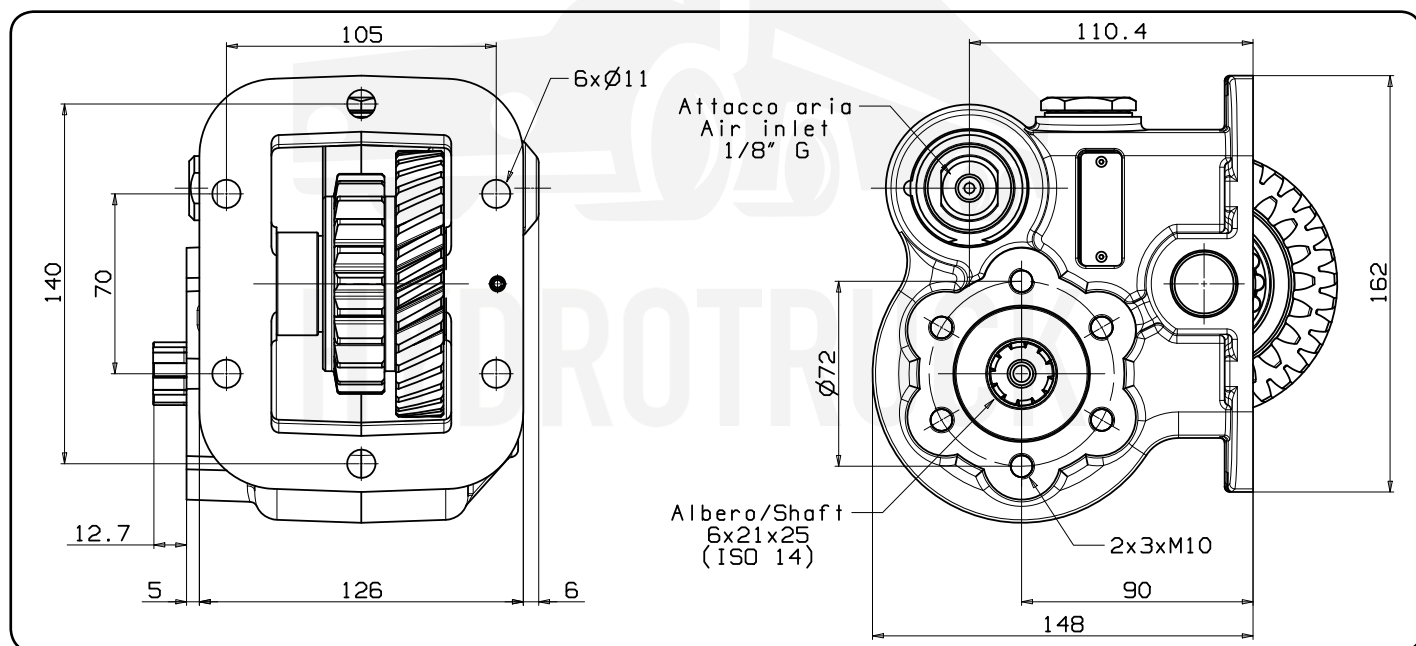
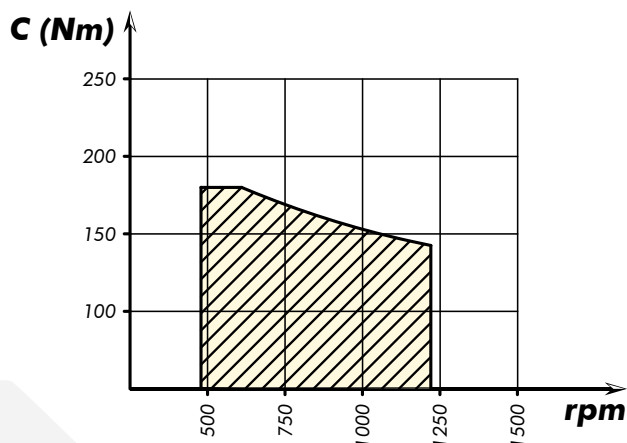

Tipo cambio Gearbox	Codice PTO PTO code	Versione Version	Giri pto a 1000 giri motore Pto ratio@1000 eng.rpm	Coppia massima Max torque	Lato montaggio Mounting side	Uscita Output	Rotazione Rotation	Kit di montaggio Mounting kit	Peso Weight
S5-42/ 5,72-0,76	010-029-00130	13	rpm 788	Nm 180	Dx-Sx Right-Left	Poster. Rear	Ora. Cw	154-003-03053	Kg 9,8

Data: Mercoledì 07 dicembre 2016

Codice foglio: 997-210-02913 Rev: AB



www.hydrotruck.cz
info@hydrotruck.cz

Hydrotruck s.r.o.
Tovačovská 3457/4a
750 02, Přerov
Česká republika

COMPANY WITH
QUALITY SYSTEM
CERTIFIED BY DNV GL
= ISO 9001:2015 =